

**IPPC Technical Guidance Note**

# **Integrated Pollution Prevention and Control (IPPC): Intensive Farming**

## **How to comply**

**Guidance for intensive pig and poultry farmers**

**April 2006**



**ENVIRONMENT  
AGENCY**

Commissioning Organisation  
Environment Agency  
Rio House  
Waterside Drive  
Aztec West  
Almondsbury  
Bristol BS32 4UD  
Tel 01454 624400 Fax 01454 624409

© Environment Agency  
First published 2000  
This version April 2006

This document is Environment Agency copyright. We specifically allow the following:

- Internal business or personal use. You may use this document for your own private use or for use within your business without restriction.
- Giving copies to others. You may do this without restriction provided that you make no charge.

If you wish to use this document in any way other than as set out above including in particular for commercial gain, for example by way of rental, licence, sale or providing services you should contact:

Liz Greenland  
Environment Agency  
Data and Information Exploitation Unit  
2440 The Quadrant  
Aztec West  
Almondsbury  
Bristol  
BS32 4AQ

**This is an uncontrolled document. To ensure you are using the latest version please check on the Environment Agency website [www.environment-agency.gov.uk](http://www.environment-agency.gov.uk).**

## Record of changes

### Standard Farming Installation Rules and Guidance

Version	Date	Change
1	1 Aug 2000	Initial version for use available on the website only, little changed from consultation version
2	24 Nov 2000	Revisions take into account the consultation comments and also restyling for publication
3	30 June 2001	Changed following comments received from industry
4	20 June 2005	Changed following comments from industry, experience from application, and to take account of Intensive Livestock BREF publication

### IPPC Intensive Farming – How to comply

Version	Date	Change
1	April 2006	Fixed Permit Conditions used as conditions where possible with rules and guidance from version 4 of the Standard Farming Installation Rules. Additional guidance added for existing installations.

## Contents

<b>Introduction</b>	<b>5</b>
i. Status of this guidance	5
ii. What is IPPC?	5
iii. What is BAT?	6
iv. Modern regulation approach	7
v. Applying for a permit	7
vi. Compliance assessment and enforcement	8
vii. Environmental impacts of pig and poultry installations	9
viii. Structure and content of this guidance	13
<b>1. Management</b>	<b>15</b>
1.1 General management	15
1.2 Accidents that may cause pollution	18
1.3 Energy efficiency	19
1.4 Efficient use of raw materials	21
1.5 Avoidance, recovery and disposal of wastes produced at the installation	23
1.6 Site security	24
<b>2. Operations</b>	<b>26</b>
2.1 Closure and decommissioning	26
2.2 Site protection and monitoring programme	27
2.3 Livestock numbers and movements	28
<b>3. Emissions and monitoring</b>	<b>29</b>
3.1 Emissions to water, air or land	29
3.2 Emissions to groundwater	30
3.3 Diffuse emissions of substances	30
3.4 Odour	35
3.5 Noise and vibration	36
3.6 Monitoring	37
<b>4. Information</b>	<b>38</b>
4.1 Records	38
4.2 Reporting	40
4.3 Notifications	40
<b>5. Pig rearing</b>	<b>43</b>
5.1 Selection and use of pig feed	43
5.2 Housing design and management	44
5.3 Slurry and manure storage	49
<b>6. Poultry production</b>	<b>53</b>
6.1 Selection and use of poultry feed	53
6.2 Housing design and operation	54
6.3 Slurry and manure storage	59

<b>7.</b>	<b>Slurry spreading and manure management planning</b>	<b>63</b>
7.1	Off-site activity	63
7.2	On-site activity	63
<b>References and contact details</b>		<b>70</b>
<b>Appendix 1</b>	<b>Protocol for sampling slurry and solid manure for analysis</b>	<b>77</b>
<b>Appendix 2</b>	<b>Minimising emissions from new pig housing - examples of housing designs from the BREF</b>	<b>79</b>
<b>Appendix 3</b>	<b>Minimising emissions from new poultry housing - examples of housing designs from the BREF</b>	<b>91</b>
<b>Appendix 4</b>	<b>Rule under development</b>	<b>106</b>

## Introduction

### i. Status of this guidance

This guidance has been produced by the Environment Agency, in consultation with the Scottish Environment Protection Agency (SEPA) and the Northern Ireland Environment and Heritage Service (EHS). It has been developed in discussion with:

- British Egg Industry Council
- British Poultry Council
- Department for Environment, Food and Rural Affairs (Defra)
- Meat and Livestock Commission
- National Farmers Union
- National Farmers Union Scotland
- National Pig Association
- UK Egg Producers Association
- UK Free Range Egg Producers Association

Other bodies such as Assured British Meats, ADAS, Scottish Agricultural College, Cranfield University, Silsoe Research Institute and AEA Technology have provided technical support.

### ii. What is IPPC?

The Integrated Pollution Prevention and Control (IPPC) Directive controls the environmental impacts of certain industrial activities. Its aim is to apply Best Available Techniques (BAT) to prevent, or reduce, emissions to air, land and water from these activities.

In the UK, the IPPC Directive is implemented through the English and Welsh, the Scottish, and the Northern Irish versions of the Pollution Prevention and Control (PPC) Regulations.

PPC applies to larger pig and poultry farms with capacity for more than:

- 750 sows
- 2,000 production pigs over 30kg
- 40,000 poultry (includes chickens, layers, pullets, turkeys, ducks, guinea fowl and quail)

Pigs reared outdoors are excluded from PPC, but free-range poultry (egg-laying and chickens reared for meat) are included. Farms regulated under PPC require a permit to operate. The permit will cover all aspects of farm management, from feed delivery to manure spreading. Animal welfare is not dealt with by PPC. You must comply with appropriate animal welfare standards in the design and operation of the farm.

PPC uses terms such as 'installation', 'site', 'operator' and 'activities'. We have used these terms throughout this document. Definitions and further information on this is in the Defra [Practical Guide](#) and the Environment Agency document 'Interpretation of an Installation for the Intensive Farming Sector'.

### iii. What is BAT?

**Best Available Techniques (BAT):**

*The most effective and advanced stage of development of activities and their methods of operation which indicates the practical suitability of particular techniques to prevent and where that is not practicable to reduce emissions and the impact on the environment as a whole. For these purposes: "available techniques" means "those techniques which have been developed on a scale which allows implementation in the relevant industrial sector, under economically and technically viable conditions, taking into consideration the cost and advantages, whether or not the techniques are used or produced inside the United Kingdom, as long as they are reasonably accessible to the operator"; "best" means "in relation to techniques, the most effective in achieving a high general level of protection of the environment as a whole" and "techniques" "includes both the technology used and the way in which the installation is designed, built, maintained, operated and decommissioned".*

This document contains the conditions that set out the ways in which you can meet the requirements for BAT on your installation. These conditions build on and replace the Standard Farming Installations Rules. They comprise management practices, structures and husbandry techniques at the installation – they are not prescriptive but any deviation from the conditions needs to give equivalent environmental protection. A key principle of the Pollution Prevention and Control regime is that operators will use BAT to suit the local circumstances. Much of this guidance is based on the BAT Reference Document (BREF) for Intensive Rearing of Poultry and Pigs produced by the [European IPPC Bureau](#). You can refer to this BREF for more detailed information on BAT at the European level. Appendices 2 and 3 contain examples of housing designs from the BREF for reference.

New and extended installations must use these techniques or techniques that give equivalent levels of environmental protection from the date of operation (of the new or extended part) and should require few or no improvements at the time of permitting. We recognise that new techniques cannot be brought into effect overnight on any installation, especially on existing installations where capital investment has been limited by poor economic returns. However, we expect the industry to adopt best practices and new technologies and to make continual improvements as deemed necessary by the activities taking place and the sensitivity of the local environment. Existing installations will be expected to implement, where necessary, a structured programme of improvements to management practices and to invest in structures that will reduce emissions to air, land or water. The Environment Agency has set itself a target date of 2020, by which time we intend that all permitted installations will be achieving equivalent standards of environmental protection.

Priority areas will be:

- storage of oils and materials
- integrity of buildings
- management of drainage systems
- management of manure and slurry systems

We have agreed a timetable for improvements, applicable to the sector, through discussion with industry representatives. These are included within this document.

We seek reductions in emissions from existing housing primarily through management changes, with structural changes prioritised on the basis of cost-effectiveness, local needs (for example, to address environmental targets or nuisance) and to fit with the investment cycle at the installation.

#### **iv. Modern regulation approach**

Modern regulation is outcome-focused and risk based. In this document we have used 'high level', outcome focussed conditions, supported by guidance, which makes it clear that it is for you to manage your installation in a way which meets these outcomes or objectives.

The advantages of these high level conditions include:

- They give you flexibility as to how to achieve them. They should therefore minimise the cost of compliance.
- They allow us to have a set of conditions with standard wording, that can be applied to any installation or activity that we issue a permit for. They should therefore increase the efficiency with which we issue permits, and ensure consistency.

We will encourage you to integrate environmental protection into your business. We will do this in the way that we write permits and subsequently interact in checking compliance, enforcement, charging and reporting of performance.

If at the time of issuing a permit we know that there is a problem, for example your installation causes odours which annoy neighbours, we would agree improvement conditions or an odour management plan with you. These will specify the steps you should carry out and may well require further improvements. As long as you comply with this we will not take enforcement action. This would apply similarly for any other aspect of your operations such as noise or emissions.

If, during subsequent operation, say noise becomes a problem because of encroaching housing, we have the powers to insist that a suitable management plan is implemented.

This guidance supports the standard conditions and should be used when completing your application form. The status of this guidance is that it informs you of our expectations. Unlike the permit conditions it is not legally binding. Both regulator and those regulated (and other bodies) can use it in preparation of applications, during determination of the permit conditions and subsequent compliance and in the course of any dispute arising from your permit.

Prior to an incident occurring our officer may consider that the risks of an incident need to be reduced and will use the guidance in that regard. This would be the subject of discussion and would normally be dealt with by agreement in writing. If it is not possible to reach agreement the officer may issue an enforcement notice. If you believe that the requirement is unreasonable you can appeal, initially to line management but in any case to the Secretary of State (Defra) for installations in England or the Welsh Assembly Government for installations in Wales.

#### **v. Applying for a permit**

We will issue a 'Standard Farming Permit' to a farming installation, referred to as a 'permit' in this document. To obtain a permit, you need to submit an application to the Environment Agency. This will consist of an application form and supporting documentation. This will include an application site report, site plans and assessment of environmental impacts, and might include an odour or noise management plan. A fee is due on application, to cover the costs of assessment.

We will be reasonable and take a practical approach in assessing the application. As required by the PPC Regulations we will actively consult with a number of bodies before issuing a permit e.g. Local Authorities, Health Authorities, English Nature and Countryside Commission in Wales. We will also inform the general public that an application has been submitted and place a copy in Public Registers for inspection. The PPC Regulations also require you to advertise your application in one or more newspapers.

Applications, permits and details of Environment Agency decisions will be placed in Public Registers for scrutiny.

We expect to issue a permit in most cases. We may refuse a permit where EU environmental targets are exceeded (such as air quality limits for particulate matter or critical loads for ammonia), but we will consider the individual installation contribution to any excess, and the scope for any improvements that will reduce emissions in each case.

Once granted, a permit can be reviewed at any time and must be reviewed from time to time. When a permit is reviewed any changes in the conditions, such as the addition of conditions currently being developed, will be applied from that time onwards.

### **v.i Management Plans**

You are required to submit an odour or noise management plan as part of your application where your installation meets the following criteria:

- there are sensitive receptors within 400m of the installation; or
- the installation has been the cause of odour or noise complaints.

You do not need to produce a management plan for odour or noise if there are no sensitive receptors within 400m of the installation or your installation has not been the cause of odour or noise complaints.

An odour management plan describes the measures you will take to manage odour from the installation. You can get further information on how to write an odour management plan in the Environment Agency guidance 'Odour Management at Intensive Livestock Installations' (see section 3.4).

A noise management plan describes the measures you will take to manage noise from the installation. You can get further information on how to write a noise management plan in the Environment Agency guidance 'Noise Management at Intensive Livestock Installations' (see section 3.5).

If you spread manure/litter/slurry on your own land you are required to produce a manure management plan (see section 7.2.1). This does not need to be submitted as part of your permit application but will be checked as part of compliance assessment.

### **vi. Compliance assessment and enforcement**

The conditions within the permit apply once the permit is granted, and a subsistence fee is due (paid annually). Environment Officers from local offices will assess compliance. These officers will, periodically, assess reviews and plans, investigate any complaints, carry out site inspections and agree improvement programmes. Collectively these will contribute to compliance assessment.

It is an Environment Agency principle, that where breaches of permit conditions are identified, we will firstly offer information and advice to those we regulate, resolving issues co-operatively to avoid unnecessary cost. Where negotiation fails, we will use enforcement and/or suspension notices provided by the PPC Regulations.

Where a criminal offence has been committed, the Environment Agency will consider instituting a prosecution, administering a caution or issuing a warning in addition to any other enforcement action. Further information is available from our Enforcement and Prosecution Policy, which is available from our website.

Operating without a valid permit is a criminal offence. This applies to new and expanded installations already. For existing installations, providing you make an application for a permit by 31<sup>st</sup> January 2007, you can continue operating pending the Environment Agency's permitting decision, but would be considered to be operating illegally if you do not make a permit application by this date.

## **vii. Environmental impacts of pig and poultry installations**

To help you to put the principles of PPC into action it is important to understand how and why your installation affects the environment. The main issues are the potential polluting emissions, either from normal operations or accidents and the use of raw materials.

### **vii.i Emissions from pig and poultry installations**

Pig and poultry installations affect the environment by releasing pollutants including:

- ammonia
- nutrients from manure/litter/slurry
- effluent discharges
- dust
- odour and noise

The effects of these emissions could include:

- damage to ecosystems
- acidification
- eutrophication
- the build up of substances in soils
- adverse effects on human health
- reduction of amenity

The Environment Agency has given high priority to addressing these emissions. They will be the key issues to focus on in your PPC application.

You will often find that addressing one pollutant will help to reduce the emissions of another pollutant, for example, reducing emissions of ammonia will also reduce odour emissions.

The emissions from pig and poultry installations are considered in more detail below and the measures for reducing these emissions outlined.

#### **Ammonia**

Ammonia is a gas that is directly emitted from livestock and from manure, litter and slurry. It can directly damage vegetation and it contributes to eutrophication and acidification of sensitive habitats.

The UK is signed up to a number of national drivers that aim to reduce atmospheric pollutants. The 1999 UNECE Gothenburg Protocol to Abate Acidification, Eutrophication and Ground-Level Ozone (under the Convention on Long-Range Transboundary Air Pollution), and the EU National Emission Ceilings Directive 2001, commit the UK to achieving a reduction in ammonia emissions to an annual ceiling of 297kt by 2010. Emissions are reported, by the Government, annually in the UK's National Atmospheric Emissions Inventory. In 2003 total ammonia emissions were 300kt with more than 80% originating from agriculture.

Recent research suggests that over 11% of the UK agricultural emissions of ammonia arise from pig farming and over 17% arise from poultry farming. A large proportion of this is emitted from animal housing with 7% of agricultural emissions from pig housing and 9% from poultry housing. These emissions contribute to the UK annual emissions and have an impact on local sensitive habitats.

In order to contribute to meeting this target, pig and poultry buildings must be constructed and operated, and manure/slurry/litter must be stored and spread, to minimise ammonia emissions.

For pigs, techniques to abate ammonia emissions will depend on the type of housing and the slurry or manure collection systems being used. For slurry based systems the techniques mostly aim to reduce the emitting surface of the slurry, and to reduce the area of flooring which is damp, or where dung and urine can mix above slats. For manure based systems, generous use of straw will bind nitrogen and reduce the release of ammonia. This is covered in section 5.2.

For poultry housing, the largest single influence on emissions of ammonia, and of dust, is the quality of the litter. This is affected by temperature and ventilation, drinker type and management, feeder type and management, litter material and depth, condensation, stocking density, feed formulation and quality, and bird health. Techniques aim to increase the dry matter content of the manure, by both preventing spillages of water and providing a drying mechanism. If the dry matter content is 60% or above, ammonia emissions are minimal. New buildings should be able to meet this criterion. This is covered in section 6.2.

Spreading of manure and slurry can result in ammonia (and odour) emissions to air. The UNECE Gothenburg Protocol commits the UK to a 30% reduction in emissions of ammonia from manure application compared to a 1990 baseline. Rapid incorporation is an important factor in reducing emissions to air and will help to maximise the benefit of the manure, litter and slurry spread. This is covered in chapter 7.

### **Nutrients in manure/litter/slurry**

#### ***Manure and slurry definitions:***

- *Manures may be either slurries or solid manures.*
- *Slurries consist of excreta produced by livestock whilst in a yard or building mixed with rainwater and wash water and, in some cases, waste bedding and feed. Slurries can be pumped or discharged by gravity.*
- *Slurry includes duck effluent, seepage from manure and wash water.*
- *Solid manures include farmyard manure (FYM) and comprise material from straw-based housing systems, excreta with lots of straw/sawdust/woodchips in it, or solids from mechanical separators.*
- *Most poultry systems produce solid manure (litter).*
- *Solid manure can generally be stacked.*

Manure, litter and slurry from intensive livestock are potentially valuable sources of plant nutrients, but may also be the cause of pollution. When spread at the correct time in the year and in quantities linked to crop requirements they are a valuable resource. But spread without proper planning the nutrients run-off to watercourses and leach to groundwater, contributing to nutrient enrichment and eutrophication. Due to its more liquid state, slurry is more likely to pollute water than manure. This is covered in chapter 7.

It is important to demonstrate that you are making the best use of slurry and manure on the installation, and that pollution risks are being minimised by avoiding spreading in certain locations and conditions. A manure management plan will address this. The nutrients nitrogen, phosphorus and potassium (N, P, K) in the manures should be fully accounted for in terms of soil nutrient status, crop uptake and nutrient requirements. This is covered in chapter 7.

***Slurry and manure treatment:***

*There are various options for slurry treatment, including screening, separation, aeration and anaerobic digestion. Manure can be composted. These may be of use in specific locations, where particular problems occur, or example, odour nuisance. However none have clear benefits which would be suitable for every farm. Treatment may be more practical where several local units are available to provide the necessary throughput, although biosecurity risks must be assessed.*

*The use of treatment techniques would be covered by site specific conditions.*

*The use of biogas digestion processes that exceed 0.4MW thermal input (gross) is an activity itself requiring a permit under IPPC.*

*More information about slurry and manure treatment is available from the Defra Codes of Good Agricultural Practice for Water and for Air.*

**Effluent discharges**

Surface water and groundwater may be polluted by a number of substances that can arise from your installation:

- Where fans vent to the roof this may result in dust settling on the roof. This dust will be contaminated with ammonia and other substances and when it rains these can be washed into gutters and then into drainage systems. This can cause pollution if allowed to enter watercourses without treatment.
- Yard areas can be a source of polluting effluents due to animal movements, transfers of feed and manures. The quantities of contaminants (including ammonia, particles, metals) arising from intensive livestock installations is contributing to diffuse pollution (non point source pollution) and needs to be addressed. Wherever possible clean yard areas should be kept clean and runoff managed from dirty yards.
- When houses are cleaned this can generate a polluting discharge containing manure and disinfectants. This wash water must be contained and must not be allowed to enter surface or groundwater. It should either be spread to land or disposed of off site.

This is covered in sections 3.1, 3.2 and 3.3.

## **Dust**

Dust originates from bedding, feed and the animals themselves. Dust can be a local issue for poultry installations, especially as broilers reach the end of the cycles. It may be a problem particularly for larger birds.

Dust can be a source of nuisance, odour and air pollution and may affect human health. Techniques to manage dust will vary from site to site and will depend on the practices on the installation. This is covered in section 3.3.

## **Odour and noise**

Odour and noise can affect people living near your installation and can be a source of nuisance.

Animals are inherently odorous and so the nature of intensive livestock operations means that preventing odour generation at source is rarely possible.

Odour arises primarily from the presence of manure/slurry and the biological changes which take place as it decomposes, and also the body odour of the livestock. Some odour also occurs as a result of cleaning houses and from storing manure or slurry in the open.

The odour associated with livestock housing tends to be related to ammonia but other components, such as hydrogen sulphide, can also be present. High ammonia concentrations usually accompany high odour concentrations in broiler buildings where litter is in poor condition and is too wet. Many of the actions taken to minimise odour will also minimise ammonia. This is covered in section 3.4.

Noise is generally a site-specific issue, particularly in relation to feed and livestock deliveries and manure removal. The location of fans leading to nuisance may be more widespread. Pigs tend to generate more noise in anticipation of feeding. Many of the solutions to noise issues will also complement odour control. Good management, consideration and maintaining plant and equipment can prevent many noise problems. This is covered in section 3.5.

## **vii.ii Accidents**

Accidents and emergencies can happen on any installation which could result in polluting discharges affecting the environment. You will need to prepare an accident management plan which will set out what to do in order to minimise the environmental impact of any polluting releases. This is covered in section 1.2. Accidents may lead to the release of the following pollutants:

- Oil – this is toxic to plants and animals and it can devastate river life by forming a thin film on the water surface and stopping oxygen getting to organisms. Oil spilt on the ground can pollute groundwater. Oil may be lost from unbunded storage facilities due to spillage, leakage or physical damage. Bunding an oil storage facility is an effective way of containing spilt oil.
- Pesticides – these are often highly toxic to aquatic life and may cause watercourses to fail Environmental Quality Standards. They should be stored within an area capable of retaining any spillage and protected from fire and frost.
- Foodstuffs – these are highly polluting if allowed to enter watercourses. They should be stored and managed so that spillages are contained.

These points are covered in section 3.3.

### **vii.iii Resource use**

You will use a range of resources and raw materials as part of your operation. PPC aims to ensure that they are used as efficiently as possible in order to reduce the use of natural resources and to reduce the amount of waste produced. Improving efficiency should also save you money.

You will need to address the use of the following resources:

- Energy - operating more efficiently by reducing the energy used will reduce emissions of carbon dioxide (a greenhouse gas). This is covered in section 1.3.
- Water – water is essential on the installation but it is important to assess whether you are making the best use of this resource. By optimising water use you will also be reducing the amount of waste water that you will have to dispose of. This is covered in section 1.4.
- Raw materials including biocides, pesticides, veterinary medicines, agricultural fuel oils and bedding – the inappropriate storage and use of such raw materials can lead to environmental pollution. You should aim to use materials that have a reduced environmental impact. This is covered in sections 1.4 and 3.3.
- Feed – the feed that animals receive is related to what is excreted in manure/litter/slurry. A diet containing more protein, and therefore nitrogen, than the animal requires will result in excess nitrogen being excreted. PPC aims to optimise protein use so that nitrogen excretion is minimised. This is achieved by using a staged feeding system with reducing protein content over the diet. This is covered in sections 5.1 and 6.1.

### **viii. Structure and content of this guidance**

The conditions that you are required to meet are presented in shaded boxes throughout this document, for example:

7.2.3.2 The operator shall take appropriate measures when spreading manure or slurry to land to prevent, or where this is not possible to minimise pollution of water.
--

These boxed conditions will be included in your permit (together with other site-specific conditions). Where possible these conditions are the same as the conditions used for all sectors regulated under PPC. These sector-wide conditions are in the following chapters:

- Chapter 1 – management
- Chapter 2 – operations
- Chapter 3 – emissions and monitoring
- Chapter 4 - information

Pig and poultry specific conditions are in the following chapters:

- Chapter 5 – pig rearing
- Chapter 6 – poultry production
- Chapter 7 – slurry spreading and manure management planning

Part B of the Pig and Poultry Application Form (Form IPPC 2 – Application for a Pig and Poultry Rearing Permit [ILF1]) contains questions that relate to chapters 1 to 7 of this document. You should work through these questions with this document as directed by the instructions in the form.

The conditions are supported by guidance notes which explain how you can meet the requirements of the condition and details of where you can get further information. A hyperlink in blue text e.g. [PPC for pig and poultry farmers](#) indicates where a document can be downloaded from a website or a useful webpage (these hyperlinks may not work in the PDF version of this document). The references and contact details chapter summarises all of the references in this document and other information produced by relevant organisations. This chapter also provides contact details for the organisations mentioned in this document.

**Unless otherwise specified, the conditions apply from the date of issue of the PPC Permit.**

There will be specific conditions in the permit to cover multiple operator installations, where more than one operator has responsibility for a permit. These will identify the responsibilities of each operator.

These conditions are subject to modification as new evidence of BAT becomes available.

# 1. Management

## 1.1 General management

- 1.1.1 The activities shall be managed and operated:
- (a) in accordance with a management system, which identifies and minimises risks of pollution, including those arising from operations, maintenance, accidents, incidents and non-conformances and those drawn to the attention of the operator as a result of complaints; and
  - (b) by sufficient persons who are competent in respect of the responsibilities to be undertaken by them in connection with the operation of the activities.
- 1.1.2 Records demonstrating compliance with condition 1.1.1 shall be maintained.
- 1.1.3 Any person having duties that are or may be affected by the matters set out in the permit shall have convenient access to a copy of it kept at or near the place where those duties are carried out.

### How can I meet the requirements of these conditions?

#### Management systems

You must have a management system that sets out how to manage the activity in accordance with the permit. You will be expected to understand the permit requirements and assess the options available for achieving them.

You must also **implement** the management system to deliver the environmental objectives. A management system will only work if it is put into practice.

Management systems in place for assurance schemes are likely to meet the majority of the requirements set out below.

The reference to "**operations**" means that you must consider how to minimise the environmental risks and impact of the normal running of the activities.

The reference to "**accidents**" is to ensure that accidents are considered. Accidents are one of the common causes of environmental incidents.

The reference to "**maintenance**" is to ensure the reliable operation of equipment and buildings. Properly maintained equipment will be available when required and achieve optimum performance without suffering breakdowns. Poor maintenance is one of the common root causes of environmental incidents.

We expect you to carry out a programme of planned preventative maintenance rather than waiting for failures before taking action. Your maintenance programme should include feed stores, manure, slurry and dirty water containment as well as structures for storing pesticides, veterinary medicines, waste products and agricultural fuel oil. You should ensure that plant such as slurry pumps, mixers, separators, spreading equipment and ventilation systems operate correctly.

You should periodically and at least annually inspect all structures and plant:

- inspections should cover signs of leakage, corrosion and structural damage, security and correct operation;
- periodic inspections should include visual appraisal of the structure or facility;

- take opportunities to inspect structures when they are empty or partially empty.

You should use the manufacturers recommended inspection and maintenance schedules, or have a written justification for using any other schedule.

**Safety note: Enclosed structures or tanks may contain lethal or explosive gases. Do not go into them. If in any doubt seek advice from the Health and Safety Executive.**

The reference to **"incidents and non-conformances"** is to ensure that you take responsibility for the environmental performance of the installation and achieving compliance with the permit. Incidents that require investigation include any malfunction, breakdown or failure of plant, equipment or techniques and any near misses. You should be able to cope with abnormal operation and return the activity to normal operation. We expect you to:

- Detect abnormal operation and investigate the causes.
- Assess the information and decide on the corrective action required.
- Implement the short-term corrective actions to return to normal operation.
- Implement the longer-term corrective actions to prevent re-occurrence of the problem.
- Take action to enable the public to know how to take action if a problem arises. We expect you to take responsibility for minimising the environmental impact of your activities and be responsive to the concerns of the local community.

The reference to **"complaints"** is also to ensure that you take responsibility for the environmental performance of your installation. We expect you to:

- Have systems in place to deal with complaints and to take appropriate measures to prevent, or where that is not possible to minimise, the causes.
- Display an identification notice at or near the site entrance so that they are informed about the nature of the site and that they can contact you or us. It should be easily readable from outside the site in daylight hours and should include the following information:
  - Emergency contact name and telephone number of the permit holder and/or operator;
  - Statement that the site is permitted by the Environment Agency;
  - Permit number;
  - Environment Agency national numbers, 0845 933 3111 and 0800 807060, (or any other number subsequently notified in writing by the Environment Agency).

### **Competence**

The objective of this part of the condition is to ensure that all staff have clearly defined roles and responsibilities, with instructions covering what they should (and should not) do. We will use these instructions when investigating incidents caused by human errors or omissions.

Staff managing, supervising or working on the activities should have received appropriate training to ensure that the activities are operated to comply with the permit requirements.

The requirements should be written for a post holder rather than for an individual.

Evidence that may contribute to you being able to demonstrate that staff meet this requirement include:

- vocational qualifications e.g. NVQs;
- attendance at external or in-house training courses;

- those with approved training to cascade that training to other staff;
- mentoring of inexperienced staff, as part of "on the job" training.

Appropriate training should include:

- how to prevent accidental releases and the actions to be taken should such an accident occur;
- awareness of the accident management plan so that staff are fully conversant with those areas relevant to their duties.
- awareness of the permit conditions for the installation, its implications, and how compliance can be secured by the work activities of the individual;
- awareness of the potential environmental effects of the installation under routine and abnormal circumstances;
- maintenance of structures and plant where these are maintained by installation staff.

Contractors should be made aware of any aspects of the permit requirements that affect their duties and be competent to undertake their relevant duties.

### **Records**

The keeping and maintenance of adequate and reliable records is fundamental to an adequate management system.

The staff competency records should include:

- the date and type of training;
- the training provider;
- how the competencies and training received meet the requirements.

Records must be kept according to the conditions set out in section 4 of the permit.

You should record any pollution incidents, such as spillage of oil or leaking stores, which may have occurred during the operation of the installation, together with the steps taken to remedy that pollution at the time. This will help to establish whether the site is in a satisfactory state if the installation is taken out of production.

### **Where can I get further information?**

A number of specific training courses are being developed and delivered by companies such as LANTRA, BPEX and Pork Chain Solutions. There may be in-house or assurance scheme training courses which meet some or all of these requirements.

## 1.2 Accidents that may cause pollution

- 1.2.1 The operator shall:
- (a) maintain and implement an accident management plan;
  - (b) review and record at least every 4 years or as soon as practicable after an accident, (whichever is the earlier) whether changes to the plan should be made;
  - (c) make any appropriate changes to the plan identified by a review.

### How can I meet the requirements of this condition?

We expect you to have an accident management plan and implement it if an accident occurs. We would expect to check the accident management plan as part of compliance assessment.

Environment Agency guidance PPG21 on pollution incident response planning (see further information below) describes how to produce an accident management plan relevant for a farming installation.

All staff should be aware of the location and contents of the accident management plan, and their responsibilities in the event of an accident.

To produce an accident management plan you should:

- Identify events or failures which have the potential to cause adverse environmental impacts, including:
  - Areas where the spillage or leakage of liquids could cause pollution, such as slurry tank failure or when housing is cleaned out and there is potential for litter/manure/slurry/cleanout water to be spilt. The surfacing and drainage of the area around the housing needs to capture and prevent the spread of any such spillage.
  - Vulnerable locations, such as areas where foodstuff is stored with high levels of motorised traffic.
  - The location of any diverter valves.
- Assess the likelihood of these occurrences and the potential environmental consequences;
- Take action to minimise the potential causes and consequences of accidents; and
- Identify the actions to be taken to minimise the consequences should such accidents occur.

You should keep a site layout plan, showing details of all surface and foul drains, in the site office, with a back-up copy elsewhere in case the office is inaccessible in an emergency.

The raw materials inventory should be included in the plan.

If an accident does occur that has the potential to cause, or does cause, an adverse environmental impact you must:

- immediately undertake any action required by the accident management plan;
- undertake any other action required to minimise the environmental consequences; and
- investigate the causes of the event and take action to prevent a recurrence.

## Review the accident management plan

Reviewing the plan after an accident or incident is an effective way of preventing particular problems from occurring again. The relevant measures identified in the review must be incorporated into the accident management plan and subsequently implemented.

### Where can I get further information?

Guidance on producing an accident management plan can be found in:

- [PPG 21](#) Pollution Prevention Guidelines – pollution incident response planning;
- Environment Agency [Factsheet 2](#) – producing a site layout plan;
- Environment Agency [Factsheet 3](#) – producing a site drainage plan;
- Environment Agency [Factsheet 4](#) - producing an accident management plan.

## 1.3 Energy efficiency

- 1.3.1 The operator shall:
- (a) take appropriate measures to ensure that energy is used efficiently in the activities;
  - (b) review and record at least every 4 years whether there are suitable opportunities to improve the energy efficiency of the activities; and
  - (c) take any further appropriate measures identified by a review.

### How can I meet the requirements of this condition?

**If you are subject to a Climate Change Levy Agreement then this will meet the requirements of this condition and you do not need to undertake an energy review.** You should provide the reference number of your agreement, as evidence, as part of your permit application. Once permitted you will need to show the agreement to the Environment Agency officer as part of compliance assessment.

If you are not subject to a Climate Change Levy Agreement you should carry out an energy review and make this available to the Environment Agency. This will be checked as part of compliance assessment.

The review should be completed within four years of the date of the permit.

Records should be kept of reviews and made available to the Environment Agency on request. You should implement any measures for improvement that you have identified following your review of energy use. You should discuss these measures and when you will implement them with the Environment Agency officer.

There are a number of audit guides and packages which will help you to produce an energy review, for example, the Defra guide 'Opportunities for saving money by reducing waste on your farm' and audits from the Farm Energy Centre. These audits will make recommendations for cost-effective energy management.

Current estimates suggest that energy use at pig and poultry installations is highly variable. Many installations will find opportunities to reduce energy consumption and will see cost savings.

Where substantial heat energy is used in heating buildings there can be energy costs savings, and carbon dioxide emission benefits, in using oil or gas fired heating rather than electrical energy, providing that the energy inputs can be well controlled.

The following techniques should be considered in your review to reduce energy use on poultry installations:

- applying low energy lighting;
- insulating buildings;
- optimising the design of the ventilation system in each house to provide good temperature control and to achieve minimum ventilation rates in winter (animal welfare considerations are vital in the choice of ventilation systems);
- avoiding resistance in ventilation systems through inspection and cleaning of ducts and fans at cleanout.

The following techniques should be considered in your review to reduce energy use on pig installations:

- applying low energy lighting;
- applying natural ventilation where possible, with design of buildings and pens, and spatial planning with respect to the prevailing wind directions to enhance the airflow (animal welfare considerations are vital in the choice of ventilation systems);
- mechanically ventilated houses optimised design of ventilation systems in each house to provide good temperature control and to achieve minimum ventilation rates in winter (animal welfare considerations are vital in the choice of ventilation systems);
- mechanically ventilated houses optimised to avoid resistance in ventilation systems through frequent inspection and cleaning of ducts and fans;
- reuse of waste heat e.g. from slurry cooling systems for purposes such as heating farrowing accommodation.

#### **Where can I get further information?**

Examples of energy audits:

- [Opportunities for Saving Money by Reducing Waste on Your Farm](#), Defra;
- [Farm Energy Centre](#) audits.

A range of publications on energy efficiency for [poultry production](#) and [pig rearing](#) can be ordered from the Farm Energy Centre.

The Carbon Trust has produced an Energy Consumption Guide '[Energy Use in Pig Farming](#)'.

## 1.4 Efficient use of raw materials

- 1.4.1 The operator shall:
- (a) take appropriate measures to ensure that raw materials and water are used efficiently in the activities;
  - (b) maintain records of raw materials and water used in the activities;
  - (c) review and record at least every 4 years whether there are suitable alternative materials that could reduce environmental impact or opportunities to improve the efficiency of raw material and water use; and
  - (d) take any further appropriate measures identified by a review.

### How can I meet the requirements of this condition?

#### Records of raw materials

You should maintain an inventory detailing quantities and relevant environmental characteristics of the raw materials used. These records should be maintained in a format equivalent to that supplied in your permit application and should be made available to the Environment Agency on request. The raw materials inventory should be included as an appendix to the accident management plan. The inventory should cover:

- biocides (including disinfectants, wood preservatives, slimicides);
- pesticides (including herbicides, fungicides, insecticides, vertebrate control products, biological pesticides);
- veterinary medicines;
- agricultural fuel oils and lubricants;
- bedding.

Disinfectants, pesticides and veterinary medicines on an approved list (see further information below) do not need to be listed individually. You should make reference to:

- the category of materials used;
- whether they are from an approved list;
- the total quantities used each year;
- the total quantity stored on site.

Products not on approved lists should be listed individually by trade names or by active ingredients. Manufacturers safety data sheets, or COSHH data sheets, including information on potential environmental harm, should be supplied.

Volumes or weights of veterinary medicines held on site for general purposes should be listed. Usage of veterinary medicines should be recorded on NOAH record sheets or equivalent, and held on site. You do not need to anticipate disease outbreaks, such as Classical Swine Fever or Foot and Mouth Disease, the intention is to show what medicines would be stored on site in normal circumstances.

A description of the types of bedding used should be given. You do not need to record the quantities stored.

Foodstuffs are covered in sections 5.1 and 6.1 and do not need to be included in this section.

### **Records of water use**

You should measure how much water is used on the installation using a water meter. Water use figures should be recorded and water consumption monitored.

Responsibility for monitoring and managing water use should be allocated to a member of staff.

Water meter readings should be taken and recorded monthly, for example, on the first or last day of the month. This will enable you to monitor water consumption and identify any water leaks.

### **Review and record raw materials use**

You should review the raw materials used on your installation every four years and identify whether there are alternatives that:

- are more effective;
- are safer for the operator to use;
- have fewer impacts on the environment;
- mean less product is needed to do the job.

You should record this information and make it available to the Environment Agency. This will be checked as part of compliance assessment.

### **Review and record water use**

You should carry out a review of water use and make this available to the Environment Agency. This will be checked as part of compliance assessment.

The review should be completed within four years of the date of the permit. You should produce a plan for optimising water use in the areas identified in the review.

See 'further information' below for examples of water audits.

The review should consider the following measures:

- a plan identifying all water supply and distribution pipework for water at the installation;
- insulating exposed water pipes above ground, or installing suitable systems to reduce the risk of freezing pipes;
- installing stop taps and drain valves in the water distribution system;
- installing covers on water tanks;
- fitting hoses, hand lances and washing equipment with trigger controls;
- taking measures to pinpoint leaks and excessive use;
- identifying the position of the water meter;
- brushing, scraping or squeegeeing dirty areas before washing down;
- cleaning housing and equipment with high-pressure cleaners for a short duration after each production cycle;
- annual calibration of drinking water installations and meters.

### Implementing measures from the reviews

You should implement any measures for improvement that you have identified following your review of the use of raw materials and water. You may wish to discuss these measures and when you will implement them with the Environment Agency officer.

### Where can I get further information?

A raw materials proforma is in the IPPC Pigs and Poultry Application Form.

Approved lists of disinfectants, pesticides and veterinary medicines are:

- [Defra/HSE Guide to Pesticides](#) (The Blue Book) Electronic Copy (previously referred to as Defra/HSE Reference Book 500);
- [National Office of Animal Health](#) (NOAH) compendium;
- [Defra's approved list of disinfectants](#).

Examples of water audits:

- [Waterwise on the Farm](#), Environment Agency/NFU/LEAF guidance;
- [Opportunities for Saving Money by Reducing Waste on Your Farm](#), Defra.

## 1.5 Avoidance, recovery and disposal of wastes produced at the installation

1.5.1 The operator shall:

- (a) maintain records of waste produced by the activities and records of wastes sent off site from the activities, for either disposal or recovery;
- (b) take appropriate measures to ensure that waste produced by the activities is avoided or reduced, or where waste is produced it is recovered wherever practicable or otherwise disposed of in a manner which minimises its impact on the environment;
- (c) review and record at least every 4 years whether changes to those measures should be made; and
- (d) take any further appropriate measures identified by a review.

### How can I meet the requirements of this condition?

You should keep records of the waste produced by the activities on your installation. You should also keep records of the wastes sent for disposal or recovery. These records will help you to review your waste management. You should carry out a waste minimisation review within four years of the date of the permit and make this available to the Environment Agency. This will be checked as part of compliance assessment.

The review should consider the following:

- can you avoid producing a waste?
- can you reduce the amount of waste produced?
- where waste is produced can it be recovered or recycled?

- is the waste disposed of in accordance with the Agricultural Waste Regulations so that the environmental impact is minimised?

The review should have a content equivalent to the Defra guide 'Opportunities for Saving Money by Reducing Waste on Your Farm'.

The sections which should be completed include:

- veterinary products
- carcasses
- feed waste
- fuel oil and lubricants
- scrap metals
- tyres
- packaging

You should implement measures for reducing waste quantities in any areas identified in the review. You may wish to discuss these measures and when you will implement them with the Environment Agency officer.

Any waste stored on the installation should be managed so that it does not cause pollution:

- safely contained so that it remains in your control (e.g. not blown away);
- is stored on an impermeable surface that is treated as a contaminated yard (see section 3.3).

The PPC Regulations require the site of the installation to be restored to a satisfactory state before the permit can be surrendered (on closure of the installation). The presence of any waste residues on the site at that time could prejudice the acceptance of the site as finally restored.

### **Where can I get further information?**

Example of a waste minimisation audit:

- [Opportunities for Saving Money by Reducing Waste on Your Farm](#), Defra.

The Defra [Agricultural Waste](#) web pages have more information on the Waste Management (England and Wales) Regulations 2006 and the controls that apply to agricultural waste.

## **1.6 Site security**

1.6.1 Site security measures shall prevent unauthorised access to the site, as far as practicable.
--

### **How can I meet the requirements of this condition?**

The objective of this condition is to ensure that the site is secure to prevent vandalism, which is a common cause of pollution incidents. The condition does not apply to any person who has legal powers of entry or has been authorised by the operator to have access to the activities. What is appropriate will depend upon the risks posed by the activity itself and the particular location.

To comply with this condition you should provide the following:

- security checks or supervision of people entering the site during normal working hours;
- gates that are closed and locked outside normal operating hours to prevent people walking or driving onto the site;
- fences or hedges around the site perimeter that people and livestock cannot easily get through or over (livestock includes cattle, horses, sheep, goats and pigs but does not include domestic pets such as dogs and cats, or any wild animals);
- individual facilities including as slurry tank valves and oil tank outlets should be locked, and buildings should be protected from unauthorised access;
- authoritative signs of a general nature warning people not to enter the site without prior authorisation.

## 2. Operations

### 2.1 Closure and decommissioning

- 2.1.1 The operator shall maintain and operate the activities so as to prevent or where that is not practicable, to minimise, any pollution risk on closure and decommissioning.
- 2.1.2 The operator shall maintain a site closure plan which demonstrates how the activities can be decommissioned to avoid any pollution risk and return the site to a satisfactory state.
- 2.1.3 The operator shall carry out and record a review of the site closure plan at least every 4 years.
- 2.1.4 The site closure plan (or relevant part thereof) shall be implemented on final cessation or decommissioning of the activities or part thereof.

#### **How can I meet the requirements of these conditions?**

You must maintain and implement a site closure plan and make this available to the Environment Agency. This will be checked as part of compliance assessment.

The site closure plan should describe how the site would be decommissioned. It should demonstrate that there has been adequate consideration of how to decommission the installation and return the site to an acceptable state. You need to maintain and review the site closure plan at least every four years.

You should discuss any amendments or additions to the plan following any review with the Environment Agency, as part of compliance assessment.

#### **Site surrender**

Site surrender will normally follow the cessation and decommissioning of the activities. You will need to submit a surrender site report when you apply to surrender your permit. The site surrender report is intended to demonstrate that the land at a site is in a 'satisfactory state' and that pollution risks have been removed. The Environment Agency will not accept an application to surrender the permit unless it is demonstrated that there is no pollution risk and no further steps are required to return the site to a satisfactory state.

#### **Where can I get further information?**

The Environment Agency IPPC H8 '[Guidance on the Protection of Land under PPC Regime : Surrender Site Report \(Draft Consultation Version 1\)](#)' details what is required. This should be used with the [IPPC H8 Surrender Site Report Template](#).

## 2.2 Site protection and monitoring programme

- 2.2.1 The operator shall, within 2 months of the issue of the permit, submit a site protection and monitoring programme.
- 2.2.2 The operator shall implement and maintain the site protection and monitoring programme and shall carry out and record a review of it at least every 4 years.

### How can I meet the requirements of these conditions?

The requirement to produce a site protection and monitoring programme (SPMP) is site-specific. Conditions 2.2.1 and 2.2.2 in your permit indicate whether you will need to produce, implement and maintain an SPMP for your installation.

The details of the SPMP is site specific and depends on the information submitted in your Application Site Report (ASR) for the assessment on the likelihood of future pollution to land.

This is required to prevent emissions of pollutants to land throughout the life of your permit and to help you to demonstrate appropriate steps have been taken to avoid any pollution risk and to return the site to a satisfactory state at permit surrender. At the time of permit surrender the SPMP will be considered alongside additional information from your general management, monitoring, accident records and site closure plans. Satisfactory state is described by Defra as the condition of the land before the permit was granted.

The SPMP design will require agreement with the Environment Agency. You are required to keep the reporting records associated to these conditions for the life of the permit. You will need these records to demonstrate the steps you have taken to avoid pollution and to return the site to a satisfactory state at permit surrender. The monitoring results will be a major part of the assessment with an application to surrender a PPC permit.

A review of your SPMP is required to be conducted at least every four years to comply with condition 2.2.2. The main purpose of the review is to demonstrate the programme of ongoing monitoring as described in your SPMP will be effective in preventing emissions of pollutants to land throughout the life of the permit. You need to notify the Environment Agency of the results of the review and any amendment or addition to the SPMP that you consider necessary.

### Where can I get further information?

An application site report is required to be submitted as part of your permit application. This will form the basis of your SPMP where one is required. Further information is in the Environment Agency guidance 'IPPC Intensive Farming Application Site Report Guidance and Template'.

This guidance is essentially a farm-specific version of the Environment Agency Horizontal Guidance IPPC H7 '[Guidance on the protection of land under the PPC regime: Application Site Report and Site Protection and Monitoring Programme](#)' that other PPC regulated sectors use. It refers to the following templates:

- [IPPC H7 Reporting Template 2](#) - Template for Design of a Site Protection and Monitoring Programme for Installations Requiring Reference Data to be Collected.
- [IPPC H7 Reporting Template 3](#) - Template for Design of a Site Protection and Monitoring Programme for Installations, that DO NOT Require Reference Data to be Collected.

## 2.3 Livestock numbers and movements

2.3.1 The operator shall implement and maintain a system to record the number of animal places and movements.

### **How can I meet the requirements of this condition?**

You should keep a record of the number of animal places available on your installation. Note that this is the capacity of your installation and not the number of animals on the installation at any one time or over the year.

You also need to record animal movements on and off the installation.

For pigs you will be recording this information for the Pigs (Records, Identification and Movement) (England) Order 2003 (PRIMO).

These records should be made available to the Environment Agency for inspection and should be supplied on request. This information is required to estimate the emissions of ammonia to air from the installation, in place of monitoring of emissions directly.

### **Where can I get further information?**

Information on assessing the capacity of your installation is provided in the Environment Agency document 'Interpretation of an Installation for the Intensive Farming Sector'.

## 3. Emissions and monitoring

### 3.1 Emissions to water, air or land

- 3.1.1 Point source discharges to water, air or land shall not cause pollution, unless the operator has used appropriate measures, including those specified in the permit, to prevent or where that is not practicable, to minimise, those emissions.
- 3.1.2 There shall be no point source emissions to water, air or land except from the sources and emission points listed in the permit.
- 3.1.3 Any limits given in the permit shall not be exceeded.
- 3.1.4 The operator shall carry out monitoring of point source emissions as specified in the permit.

#### How can I meet the requirements of this condition?

Point source emissions include discharges of liquid from pipes to surface water and emissions from chimneys such as from an ammonia scrubber. Point source emissions are normally controlled using emission limits. Ventilation system outlets are **not** classed as point source emissions. Soakaways and swales are point source emissions to land but are not normally controlled using emission limits.

The PPC permit application form will require any point source emissions to be identified and these will be listed in the permit. There may be a few farming installations that have point source emissions that require limits and monitoring. The requirements will be applied on a site-by-site basis.

The following are the appropriate measures that we would expect you to take to comply with condition 3.1.1. The measures required to collect and control site drainage are relevant measures to prevent pollution by point source emissions to water and land (see section 3.3).

- There should be no untreated point source emissions directly into surface water.
- The treatment method should be appropriate to the contamination and the receiving water.
- Suitable treatments can include swales or constructed wetlands; settlement ponds and sediment traps; soakaways.

#### Where can I get further information?

The Environment and Heritage Service in Northern Ireland has produced guidance on constructing swales on poultry farms – [‘Guidelines for construction of swales for water quality improvement and flow attenuation of lightly contaminated runoff from poultry farms’](#).

## 3.2 Emissions to groundwater

- 3.2.1 There shall be no emission from the activities into groundwater of any substance in List I (as defined by the Groundwater Regulations) contrary to those Regulations.
- 3.2.2 There shall be no emission from the activities into groundwater of any substance in List II (as defined in the Groundwater Regulations) so as to cause pollution (as defined in those Regulations).

### How can I meet the requirements of these conditions?

The Groundwater Regulations 1998 control the discharge to groundwater (direct or indirect) of a number of substances. These substances are detailed in List I and List II to the Regulations (see further information below). Disposal onto or into land of any of these substances requires authorisation under the Groundwater Regulations, whilst use of these substances does not.

Pesticides are very likely to contain List I or List II substances. In dealing with pesticide disposal you should assume that they are all within the scope of the regulations and make arrangements which meet these requirements. Further advice can be obtained from the Environment Agency.

### Where can I get further information?

List I and II substances are detailed in the Environment Agency [Groundwater Regulations leaflet](#).

## 3.3 Diffuse emissions of substances

- 3.3.1 Diffuse emissions of substances (excluding noise and odour) shall not cause pollution, unless the operator has used appropriate measures to prevent or where that is not practicable, to minimise, those emissions.
- 3.3.2 All liquids, whose emission to water or land could cause pollution, shall be provided with secondary containment, unless the operator has used other appropriate measures to prevent or where that is not practicable, to minimise, leakage and spillage from the primary container.
- 3.3.3 A review of all site drainage shall be undertaken and submitted within 12 months of the issue of the permit. Improvements to drainage systems shall be implemented in accordance with a timetable agreed with the Agency.

For farming installations, diffuse emissions are defined simply as those not listed as point source emissions in the permit (see section 3.1).

### **How can I meet the requirements of these conditions?**

The following are the appropriate measures we expect to be in place at the farm.

#### **Appropriate measures for preventing and minimising diffuse emissions**

##### ***General building and site maintenance***

- You should maintain buildings in good repair to minimise water leaks into the house which may increase the moisture content of litter and manure.
- You should keep areas around buildings free of any build up of manure, slurry and spilt feed.
- You should maintain impervious surfaces and containment kerbs, for example, concrete areas around buildings should be free from cracks (cracks in concrete yards can pose a risk to groundwater).

##### ***Management of drainage systems and run-off***

**You should review drainage within 12 months and implement improvements to a timetable agreed with the Environment Agency (12 months onwards).**

The measures required for point source emissions are relevant measures to prevent pollution by diffuse emissions to water and land (see section 3.1).

It is acceptable for drainage from **clean** yards to drain to surface waters.

- All drainage systems should be identified in the accident management plan.
- Clean water drainage systems should not be contaminated. Under no circumstances should slurry (including seepage from manure) be allowed to enter surface water drains or drain into the ground.
- The contamination of yard areas should be minimised to reduce the amount of contaminated water that requires disposal. This should include:
  - keeping yards visibly clean;
  - keeping drainage channels clear;
  - cleaning up accumulations of spilt feed and dust.
- Drainage from animal housing and water from cleaning out is considered to be slurry and should be collected in a tank or lagoon prior to landspreading or disposal.
- Drainage from yards in regular use by livestock, or likely to be contaminated by manures or slurries should be collected in slurry or dirty water tanks.
- Tanks and collection systems should be designed and constructed to deal with the volumes to be contained.
- Where the ventilation system has outlets through side-walls, interception is required before drainage reaches surface water systems. Interception may include grassed areas, swales or collection pits.
- Where side-wall outlets are located above grass areas, further interception is not required provided that the grass cover is sufficient to collect the dust and to impede run-off to surface water systems.
- Where side-wall outlets are located above yard areas, the dust should be removed regularly (so that the yard is kept visibly clean).

- Roof water from housing where there are no roof outlets does not require interception and treatment.
- Where yards are at times clean and at other times have traffic of vehicles and or livestock over them, drainage should pass to surface water systems only during the clean times.
- Procedures should be put in place to prevent contamination of surface water systems and divert drainage to slurry or dirty water tanks at other times. This can be achieved through the use of temporary bunds around drains, diverter valves or drain blockers.
- Where diverter valves are used to direct dirty water from yards to storage tanks the following measures should be taken:
  - the location of the diverter valve should be detailed on the accident management plan;
  - responsibility should be allocated to a member of staff for management of the diverter valve.

#### ***Disinfectant footbaths***

- Disinfectant footbaths should not overflow.
- Spent disinfectant from footbaths and wheel washes should be added to the manure or slurry store contents and applied to land in accordance with the manure management plan or added to the liquid storage tanks and exported from the site.
- Wheelwashes should be pits lined with impermeable material.

#### ***Foodstuff***

**These appropriate measures should be in place no later than six months from the date of issue of the permit.**

- You should store dusty or potentially dusty foodstuff materials in covered containers, purpose-built silos or under cover.
- The transfer of foodstuff to and from storage areas should be carried out so as to prevent or minimise dust emissions to air.
- The milling and mixing of dry foodstuff on your installation should be carried out so as to prevent or minimise dust emissions to air.
- Measures may include extraction and abatement of dust from feed preparation areas.

#### ***Housing ventilation***

- Upgraded or replacement ventilation systems should be designed to achieve the optimum air quality conditions for the stage of production in all weather and seasonal conditions.
- All ventilation systems should be operated to achieve the optimum air quality conditions levels for the stage of production in all weather and seasonal conditions.
- Control of minimum ventilation rates should be planned to avoid the build-up of moisture (humidity) in the house.
- Ventilation should be appropriate to the age, weight and health of the animal.

### ***Poultry litter management***

**These appropriate measures for poultry litter management should be in place no later than six months from the date of issue of the permit.**

Litter quality results from a complex interaction of factors such as ventilation, temperature, humidity, diet, stocking density, and management. To avoid excess emissions, litter should be maintained in as dry and friable condition as possible.

Duck housing is not expected to maintain dry and friable manure due to the physiological and behavioural requirements of ducks for water, but you may be asked to justify your selection of drinker. Water use by ducks should be within the normal range for the age of the bird.

- For poultry installations, you must take all reasonable steps to ensure that poultry litter is maintained in as dry and friable condition as possible.
- Any situation which results in over-wet litter should be managed to bring it back to a friable condition as soon as possible.
- Poultry drinkers should be chosen and managed to maintain dry and friable litter.
- Drinkers should be at the correct height and the height should be adjusted as the birds grow.

### ***Poultry dust management***

- Dust emissions from buildings should be minimised.
- Dust generation may be controlled within the house through the management of the litter and air quality, which needs to be balanced with the need to minimise ammonia and odour.
- Choice of litter material and feed type, and avoidance of disturbance to the birds should be used to control dust.

### ***Manure management***

- When manure and slurry is removed from housing, you must ensure that it is:
  - stored in structures that meet the requirements of the conditions in section 5.3 (pigs) or 6.3 (poultry); or
  - exported from the site; or
  - applied to land in accordance with the requirements of the conditions in chapter 7.

### ***Carcass Management***

The regulation of animal by-products is the responsibility of the State Veterinary Service and Local Authorities. Their prime concern is the protection of animal health and human health.

- Carcasses should be disposed of in accordance with the Animal By-Products Regulations 2003.
- Carcasses should not be buried on the installation other than in accordance with the agreed and dated accident management plan (see 1.2) under the direction of the State Veterinary Service.
- Carcasses may be disposed of off-site to the National Fallen Stock Scheme, a licensed knackerman, rendering plant, hunt kennel, maggot farm or authorised incinerator. They should be removed frequently to prevent odour nuisance and be covered to prevent access by birds or rodents using plastic bags or lidded bins where possible.

- Carcasses may be disposed of on-site in an authorised incinerator. Only carcasses may be disposed of in incinerators licensed under the Animal By-Products Regulation. Operation of an incinerator for other wastes would need to comply with the Waste Incineration (England and Wales) Regulations 2002.

### **Appropriate measures for bunding and containment**

#### ***Agricultural fuel oil and other chemicals storage***

**These appropriate measures for the storage of agricultural fuel oil and other chemicals should be in place no later than six months from the date of issue of the permit.**

Veterinary medicines are considered to be those listed by the National Office of Animal Health and do not necessarily require prescription or administration by a veterinary surgeon.

- Agricultural fuel oil, pesticides and veterinary medicines should be contained in an area capable of retaining any spillage:
  - Agricultural fuel oil storage facilities should be bunded. Oil bunds must meet the requirements of The Control of Pollution (Silage Slurry and Agricultural Fuel Oil) Regulations 1991 (amended 1997).
  - Pesticides and veterinary medicines must also be kept in a store that is resistant to fire, dry, frost-free and secure against unauthorised access.

#### ***Foodstuff***

**These appropriate measures for the containment of foodstuff should be in place no later than 12 months from the date of issue of the permit.**

- Containment should be provided for foodstuff in order to prevent spillages and minimise waste. Any foodstuff which might flow under the influence of gravity (e.g. liquid feed) should be contained. Containment should consist of:
  - a bunded area, or
  - siting the store in an area isolated from the surface-water system such that any spillage cannot enter any drainage system.
- Storage vessels for foodstuff should be protected from collision damage. Collision protection may be achieved by:
  - careful siting relative to traffic flows with measures such as provision of kerbs or other markers to stop reversing vehicles, or
  - by the use of barriers in more vulnerable locations.

#### **Where can I get further information?**

The Environment Agency's [Pollution Prevention Guidance Notes](#) cover a range of pollution prevention topics. They advise on statutory responsibilities and good practice to protect the environment.

Advice on managing poultry litter can be found in the Defra booklet [Poultry Litter Management](#) (PB1739).

The Defra [Animal By-Products Regulations](#) web pages have further information on the Animal By-Products Regulations and on incinerators.

The SSAFO Regulations can be downloaded from the Office of Public Sector Information website via the following:

- [The Control of Pollution \(Silage, Slurry and Agricultural Fuel Oil\) Regulations 1991](#). S.I 1991 No. 324;
- [The Control of Pollution \(Silage, Slurry and Agricultural Fuel Oil\) \(Amendment\) Regulations 1997](#). S.I 1997 No. 547.

You can get information and design details on constructing bunds from the following CIRIA/Environment Agencies joint guidelines:

- [Concrete bunds for oil storage tanks](#)
- [Masonry bunds for oil storage tanks](#)

You can obtain the following [Construction Guidance Notes](#) from Acorus (formerly published by ADAS):

- CGN 008 Separation of Clean and Dirty Water, Dirty Water Storage, Yard Area Construction;
- CGN 009 Bunds for Agricultural Fuel Oil Tanks.

Information on storing pesticides is in the Defra [Code of Practice for Using Plant Protection Products](#).

### 3.4 Odour

3.4.1 Emissions from the activities shall be free from odour at levels likely to cause annoyance outside the site, as substantiated by an authorised officer of the Agency, unless the operator has used appropriate measures, including those specified in an odour management plan, to prevent or where that is not practicable to minimise the odour.

3.4.2 The operator shall:

- (a) maintain and implement an odour management plan;
- (b) review and record at least every 4 years or as soon as practicable after a complaint, (whichever is the earlier) whether changes to the plan should be made;
- (c) make any appropriate changes to the plan identified by a review.

#### How can I meet the requirements of these conditions?

It is acknowledged that there is likely to be odour from a pig or poultry installation outside of the installation boundary. The conditions for this sector incorporate appropriate measures to prevent and where that is not possible to minimise these odour emissions. In certain circumstances you are required to address odour through an odour management plan (see section v.i). This odour management plan would be referenced in a Schedule to the permit. Condition 3.4.2 would only be required where an odour management plan is needed.

Requirements to control odour will be site specific, depending on the location of the installation. Many of the conditions for controlling emissions to air will have additional benefits in reducing odour.

The installation should be operated in accordance with the odour management plan.

### Where can I get further information?

The Environment Agency guidance '[Odour Management at Intensive Livestock Installations](#)' describes:

- the sources of odour on the installation and control measures;
- how to complete an odour management plan;
- the options for carrying out an odour impact assessment.

This guidance is essentially a farm-specific version of the Environment Agency Horizontal Guidance for Odour (IPPC H4: [Horizontal Odour Guidance. Part 1: Regulation and Permitting and Part 2: Assessment and Control](#)) that other PPC regulated sectors use.

Further advice on reducing odour emissions is available in the Defra [Code of Good Agricultural Practice for the Protection of Air](#).

## 3.5 Noise and vibration

3.5.1 Emissions from the activities shall be free from noise and vibration at levels likely to cause annoyance outside the site, as substantiated by an authorised officer of the Agency, unless the operator has used appropriate measures, including those specified in a noise management plan, to prevent or where that is not practicable to minimise the noise and vibration.

3.5.2 The operator shall:

- (a) maintain and implement a noise management plan;
- (b) review and record at least every 4 years or as soon as practicable after a complaint, (whichever is the earlier) whether changes to the plan should be made;
- (c) make any appropriate changes to the plan identified by a review.

### How can I meet the requirements of these conditions?

It is acknowledged that there is likely to be noise from a pig or poultry installation outside of the installation boundary. The conditions for this sector incorporate appropriate measures to prevent and where that is not possible to minimise these noise emissions. In certain circumstances you are required to address noise through a noise management plan (see section v.i). This noise management plan would be referenced in a Schedule to the permit. Condition 3.5.2 would only be required where a noise management plan is needed.

Requirements to abate noise will be site specific, depending on the location of the installation.

The installation should be operated in accordance with the noise management plan.

### Where can I get further information?

The Environment Agency guidance '[Noise Management at Intensive Livestock Installations](#)' describes:

- the sources of noise on the installation and control measures;
- how to complete a noise management plan;
- the options for carrying out a noise impact assessment.

This guidance is essentially a farm-specific version of the Environment Agency Horizontal Guidance for Noise ([IPPC H3: Part 1 – Regulation and Permitting](#) and [Part 2 – Noise Assessment and Control](#)) that other PPC regulated sectors use.

Guidance has also been produced by ADAS for Defra:

- Guidance on the control of noise on pig units;
- Guidance on the control of noise on poultry units.

## 3.6 Monitoring

- 3.6.1 Monitoring shall be carried out of the parameters set out in the permit at the specified monitoring locations and at frequencies not less than those specified in the permit.
- 3.6.2 The operator shall maintain records of all monitoring undertaken or carried out including records of the taking and analysis of samples instrument measurements (periodic and continual), calibrations, examinations, tests and surveys and any assessment or evaluation made on the basis of such data.
- 3.6.3 Within 6 months of the issue of the permit (unless otherwise agreed with the Agency) the site reference data identified in the site protection and monitoring programme shall be collected and submitted to the Agency.

### How can I meet the requirements of these conditions?

There will be few farming installations that will need to meet these conditions. Monitoring may be required, for example of ammonia, if an installation has sensitive receptors close by.

These conditions will be enforced on a site-by-site basis. Please contact the Environment Agency for further information on these conditions.

Condition 3.6.3 will only be relevant if your site was determined during permitting as posing a reasonable possibility of future pollution to land and reference data is required. The agreed design SPMP required by condition 2.2.1 and Reporting Template 4 in the H7 Guidance should be used to assist you with the information required to be collected and submitted to comply. Only reference data for specific substances and zones assessed as posing a reasonable possibility of future pollution to land will require reference data to be submitted. You are recommended to install any monitoring infrastructure agreed in your design SPMP during investigations to collect reference data (e.g. ongoing groundwater monitoring). The reference data will be used to set the land and/or groundwater quality conditions of your installation and used together with your SPMP results to determine with the Environment Agency whether or not you will be required to restore your site to reference conditions to achieve satisfactory state.

### Where can I get further information?

The Environment Agency IPPC H7 '[Guidance on the protection of land under the PPC regime: Application Site Report and Site Protection and Monitoring Programme](#)' details what is required.

[IPPC H7 Reporting Template 4](#) – Template for First Phase Reporting of the Site Protection and Monitoring Programme for Installations where Reference Data is Required.

## 4. Information

### 4.1 Records

- 4.1.1 All records required to be made by the permit shall:
- (a) be legible;
  - (b) be made as soon as reasonably practicable;
  - (c) if amended, be amended in such a way that the original and any subsequent amendments remain legible, or are capable of retrieval; and
  - (d) be retained, unless otherwise agreed in writing by the Agency, for at least 6 years from the date when the records were made, or in the case of the following records until permit surrender:
    - (i) the site protection and monitoring programme.
- 4.1.2 Any records required to be made by the permit shall be supplied to the Agency within 14 days where the records have been requested in writing by the Agency.
- 4.1.3 All records required to be held by the permit shall be held on the installation or site and shall be available for inspection by the Agency at any reasonable time.

#### **How can I meet the requirements of this condition?**

Copies of all records, audits and plans should be made available to the Environment Agency on request. Where the information forms part of a separate document, reference should be made to the whereabouts of this document.

You will need to keep the required records for a minimum of six years.

There are a number of records, reviews and plans that are produced at different times, either as part of the permit application or during the life of the installation, and in different site-specific situations. These are summarised below.

Records and plans which are required to be submitted with all applications include the:

- site report and site plans;
- raw materials inventory.

The Environment Agency will hold copies of these documents. Further copies should be provided if there are changes to record.

Plans submitted with the application, but which are not required on some sites are:

- noise and/or odour management plans.

Further copies should be provided to the Environment Agency if there are changes to record. Up to date copies of the documents should also be available in the site office.

A number of plans and records need to be in place at the time the permit is issued but do not need to be supplied as part of the application. These will be checked during compliance assessment:

- accident management plan;
- site closure plan;

- manure management plan for installations spreading manure or slurry on land owned by the operator;
- records relating to arrangements for spreading on third party land for installations disposing of manure and slurry off site;
- records relating to other arrangements for off site disposal of manure or slurry.

Some records and reviews will be generated once the installation is operational. The records and reviews that must be carried out and made available to the Environment Agency (i.e. they do not need to be supplied) are:

- energy review (installations without Climate Change Levy Agreement);
- raw materials review;
- water review;
- waste minimisation review;
- records of manure/slurry disposal and recovery off-installation;
- records to demonstrate you have implemented the manure management plan;
- records of soil/manure/slurry analysis (for installations spreading on the site);
- livestock numbers and movements;
- record of pollution incidents and remedial action for site closure plan;
- results of any monitoring carried out.

The records and plans that must be supplied to the Environment Agency are:

- existing housing and drainage improvement plan;
- proposals for covering or replacing existing slurry stores and lagoons;
- proposals for installing an impermeable base with effluent containment for pig manure stores;
- proposals for covering or replacing existing poultry manure stores and for installing an impermeable base with effluent containment.

## 4.2 Reporting

- 4.2.1 A report or reports shall be submitted to the Agency by 31 January (or other date agreed with the Agency) each year where the operator has the following information to submit:
- (a) the results of the monitoring and assessment carried out in accordance with the permit including an interpretative review of that data;
  - (b) where the operator's management system encompasses annual improvement targets, a summary report of the previous year's progress against such targets;
  - (c) details of any contamination or decontamination of the site which has occurred.
- 4.2.2 The operator shall, unless notice under this condition has been served within the preceding 4 years, submit to the Agency, within 6 months of receipt of a written notice, a report assessing whether there are other appropriate measures that could be taken to prevent, or where that is not practicable, to minimise pollution.
- 4.2.3 The results of reviews and any changes made to the site protection and monitoring programme shall be reported to the Agency, within 1 month of the review or change.

### How can I meet the requirements of these conditions?

Where you do not have the information specified in condition 4.2.1 then you do **not** need to submit a report to us.

Condition 4.2.2 is intended to require a periodic review of BAT for the installation. As the condition sets out this cannot be any more regularly than every four years. We will write to you when such a review is required. Guidance on what to provide will be sent to you with the notice.

## 4.3 Notifications

### Notifications of abnormal emissions, malfunctions and accidents

- 4.3.1 The Agency shall be notified without delay following the detection of:
- (a) any malfunction, breakdown or failure of equipment or techniques, accident, or diffuse emission which has caused, is causing or may cause significant pollution;
  - (b) the breach of a limit specified in the permit; and
  - (c) any significant adverse environmental effects.
- 4.3.2 Written confirmation of the notification required by condition 4.3.1 above shall be supplied within 24 hours.

### How can I meet the requirements of these conditions?

Examples of incidents or accidents requiring notification might be contaminated run-off causing pollution, containment failure and loss of yard washings to surface water, or a spillage of fuel oil.

You should notify any pollution incidents to the Environment Agency using the incident hotline telephone number 0800 807060. Calls are free and the hotline operates 24 hours a day, 7 days a week. During normal working hours you may be able to contact your local Environment Agency Officer or the local Environment Agency office by telephone, fax or email.

Written confirmation should usually be made by fax but could be made by email.

After an incident or accident, you need to review the accident management plan as required by condition 1.2.

### **Notification of changes of operational status**

- 4.3.3 Prior written notification shall be given to the Agency of the following events and in the specified timescales:
- (a) as soon as practicable prior to the permanent cessation of any of the activities;
  - (b) cessation of operation of part or all of the activities for a period likely to exceed 1 year; and
  - (c) resumption of the operation of part or all of the activities after a cessation notified under (b) above.

### **Notification of implementing the site closure plan**

- 4.3.4 The Agency shall be given at least 14 days notice before implementing any part of the site closure plan.

## Notification of changes in ownership

4.3.5 The Agency shall be notified within 14 days of the occurrence of the following matters, except where such disclosure is prohibited by Stock Exchange Rules.

- Where the operator is a registered company:
  - (a) any change in the operator's trading name, registered name or registered office address;
  - (b) any change to particulars of the operator's ultimate holding company (including details of an ultimate holding company where an operator has become a subsidiary);
  - (c) any steps taken with a view to the operator going into administration, entering into a company voluntary arrangement or being wound up.
- Where the operator is a corporate body other than a registered company:
  - (a) any change in the operator's name or address;
  - (b) any steps taken with a view to the dissolution of the operator.
- In any other case:
  - (a) the death of any of the named operators (where the operator consists of more than one named individual);
  - (b) any change in the operator's name(s) or address(es);
  - (c) any steps taken with a view to the operator, or any one of them, going into bankruptcy, entering into a composition or arrangement with creditors, or, in the case of them being in a partnership, dissolving the partnership.

## Climate change agreement

4.3.6 Where the operator has entered into a climate change agreement with the Government, the Agency shall be notified within one month of:

- (a) a decision by the Secretary of State not to re-certify the agreement;
- (b) a decision by either the operator or the Secretary of State to terminate the agreement;
- (c) any subsequent decision by the Secretary of State to re-certify such an agreement.

## 5. Pig rearing

This chapter contains the conditions for the processes that are specific to rearing pigs. You do not need to read this section or comply with these conditions if you do not rear pigs.

### 5.1 Selection and use of pig feed

- 5.1.1 The operator shall take appropriate measures to provide a diet which minimises the excretion of:
- nitrogen; and
  - phosphorus.

#### How can I meet the requirements of this condition?

The aim of the condition is to optimise protein use so that nitrogen excretion is minimised. The nitrogen excreted as a result of excess protein contributes to ammonia emissions to air and to nitrogen rich manure or slurry. The excretion of phosphorus should also be minimised.

**You should discuss the formulation of the diet with a nutritional advisor or supplier to ensure that the minimum dietary requirements of the animals are being met.**

As pigs age their protein requirement per kg of live weight gain falls. Where only one diet is fed young pigs are under-supplied with protein and lean growth is not maximised, and older pigs are oversupplied with protein and expend energy in excreting it.

Feeding a minimum of two diets to sows has benefits for the lifetime performance of the sow and litter and significantly reduces the amount of excess protein, and so nitrogen, fed.

The energy and protein requirements of sows vary according to their stage in the production cycle. Sows at conception, in very late pregnancy and whilst lactating have a higher requirement for protein than dry sows. Pregnant gilts may require a higher protein diet than subsequent parities.

The timing of the change from dry sow to lactating sow diet, and back again, will differ according to the genetics of the stock and management on the installation. As a guide, the lower protein diet is likely to be used for at least three-quarters of the gestation period.

A higher number of diets may be used providing that for rearing and finishing pigs, dietary crude protein levels are reduced with increasing age. There may be a need to support low crude protein diets with supplementary amino acids.

#### **Appropriate measures**

The following are the appropriate measures that you should take to comply with the condition. For **existing installations** these appropriate measures should be in place no later than **twelve months** from the issue of the permit and represent what we would expect to find when inspecting the installation.

#### ***Nitrogen***

- A minimum of two diets should be available for all pigs over the production cycle.
- **Sows**
  - for the majority of the period between weaning and farrowing, the diet for sows should be formulated to meet the nutritional requirements of the dry sow;

- for the antenatal period, during lactation, and for some time post weaning the diet should be formulated to meet the nutritional requirements of the lactating sow;
- the dry sow diet should have a lower level of crude protein than the lactating sow diet.
- **Rearing and finishing pigs**
  - Where a two-diet system is used for rearing and finishing pigs between 25 and 90kg the change over should be made at around 50 to 60kg. The latter diet should have a lower crude protein level. Where higher numbers of diets are used the change should be appropriate to the lifestage.
  - Where rearing and finishing pigs are routinely taken to weights over 115kg, a third diet shall be fed at 90kg and above with a further reduced protein level.

### ***Phosphorus***

- Phosphorus levels in rations for pigs should be reduced over their rearing and production cycle.
- The addition of digestible phosphorus, or the use of enzymes such as phytase will ensure optimum performance and maintenance, whilst limiting the excretion of phosphorus.

### ***Buildings and associated infrastructure***

- All buildings and associated infrastructure i.e. feed storage bins, should be specifically designed to allow at least a two-stage feeding regime.

## **5.2 Housing design and management**

### **5.2.1 New pig housing design and management**

5.2.1.1 The operator shall take appropriate measures in the design and management of housing to minimise the emissions from those systems.

#### **How can I meet the requirements of this condition?**

The aim of the condition is to ensure that housing and slurry systems are designed and managed to minimise releases, particularly of ammonia and odour. Minimum standards for welfare must be complied with in the design and operation of the housing on the installation.

The following are the appropriate measures that you should take to comply with the condition. They are divided into appropriate measures for design and management. We would expect to see that the relevant measures have been taken when inspecting the installation.

#### **Appropriate measures for design**

You should ensure that, **from the date of permit** issue, any new pig housing, either replacement housing or on an expanded installation, is designed in accordance with this condition. Other techniques are not excluded, but you will need to demonstrate that they qualify as BAT. These techniques apply to group or individual housing.

#### ***Drinkers and troughs***

- Drinkers and troughs should be designed to prevent leakage.

#### ***Slat design and slurry channels***

- Slat design and slurry channels should comprise:

- slats which facilitate maximum transfer of dung and urine to the transfer channels;
- channels which transfer slurry to storage facilities (and not store slurry).

### ***Sows – slurry systems***

- Slurry systems for sows should comprise either:
  - a partly-slatted floor with a reduced area manure pit; or
  - a fully or partly-slatted floor with vacuum system for frequent slurry removal.

### ***Farrowing sows including piglets – slurry systems***

- Slurry systems for farrowing sows including piglets should comprise a part or fully- slatted floor with:
  - a combination of water and manure channel; or
  - a flushing system with manure gutters; or
  - a manure pan underneath.
- Farrowing pens should provide a slurry channel at the rear of the sow, away from the feeding area.

### ***Weaners – slurry systems***

- Slurry systems for weaners should comprise a pen:
  - or flatdeck with a fully-slatted or partly-slatted floor with a vacuum system for frequent slurry removal;
  - or flatdeck with a fully-slatted floor beneath which there is a concrete sloped floor to separate faeces or urine; or
  - with a partly-slatted floor (two climate system); or
  - with a partly-slatted floor and a sloped or convex solid floor; or
  - with a partly-slatted floor and a shallow manure pit and channel for spoiled drinking water; or
  - with a partly-slatted floor with triangular slats and a manure channel with sloped side walls.

### ***Growers/finishers – slurry systems***

- Slurry systems for growers/finishers should comprise:
  - a fully-slatted floor with vacuum system for frequent removal; or
  - a partly-slatted floor with a reduced manure pit, including slanted walls and a vacuum system; or
  - a partly-slatted floor with a central convex solid floor at the front of the pen, a manure gutter with slanted sidewalls and sloped manure pit.

### ***Solid floor systems***

- Solid floor systems should comprise:
  - scraped areas that prevent ponding or build up of urine;
  - dung passages and bedded areas sloped to drain urine and prevent ponding.

### **Appropriate measures for management**

#### ***Slurry systems – slurry management and dunging behaviour***

It should be noted that there are additives on the market that claim to reduce emissions to air (ammonia, odour). The efficacy of some products has been found to be poor, and some may not be economically worthwhile.

- The area under slats should be cleared of slurry frequently i.e. when there is sufficient slurry to flow out.
- Lying areas should be kept clean through high standards of management and effective control of environmental conditions.
- Floor space allowances including partly-slatted floor space allowances should be calculated to match to the pigs requirements, as either a surplus or shortage of space can result in dunging in the lying area.
- Floors should be kept free from urine or slurry puddles through management to address puddles as they arise – scraping or washing down.
- Where water spray or dripper systems are used for weaners/growers/finishers they should be used over the slats to cool the pigs in hot weather and encourage good dunging behaviour. These should be maintained to prevent leakage or loss of water.

#### ***Solid floor systems – slurry/manure management and dunging behaviour***

- Dunging and lying areas should be clearly differentiated to ensure that the lying areas are kept clean and dry.
- Scraped areas should be operated to prevent ponding or build up of urine.
- Dunging areas should be cleaned out by scraping at least three times a week.
- Deep straw systems, bedded areas and straw yards should have sufficient straw or other bedding material to keep the lying area clean and dry, and to bind nitrogen to reduce ammonia emissions.
- Floors should be kept free from urine or slurry puddles, either through:
  - the provision of additional bedding material to soak it up, or
  - management to address puddles as they arise – scraping or washing down.

#### ***Ventilation***

- Draughts should be avoided in lying areas.
- Draughts under slatted flooring should be minimised by dividing the airspace with plastic sheet.
- Dunging areas in naturally ventilated buildings should be sited beneath air inlets.
- Lying areas should be sited under baffled inlets in low-pressure fan ventilated buildings.

#### ***Temperature***

- The minimum temperature such that pigs do not need to huddle together should be maintained.
- Where artificial heating is provided to weaners, controls should be used to match heating needs to minimise energy wastage.

- Weaner accommodation in 'umbrella buildings' should be provided with sufficient ventilation to keep manure temperatures low.

#### ***General management***

- Drinkers and troughs should be operated to prevent leakage.
- Floors and walls should be kept clean. Keeping the pigs clean will help keep walls clean.
- Cracks and damaged areas of walls should be repaired.

#### **Where can I get further information?**

Examples and descriptions of housing designs which meet the appropriate measures are described in Appendix 2. These examples are taken from the BAT Reference Document (BREF) for Intensive Rearing of Poultry and Pigs.

The following documents give advice on the management of pigs:

- [Code of Recommendations for the Welfare of Livestock: Pigs](#), Defra 2003 PB 7050.
- EU Directive 91/630/EEC Pig Welfare Directive which has been implemented in England through the [Welfare of Farmed Animals \(England\) \(Amendment\) Regulations 2003](#) S.I. 2003 No. 299. This came into force on 14 February 2003.
- [Environmental factors in pig production](#). Description of potential emissions, causes, abatement and legislation. BPEX/MLC May 1999.
- [Environmental Management for Healthy Pig Production](#), BPEX/MLC.

### **5.2.2 Existing pig housing design and management**

5.2.2.1 A review of existing pig housing structures and management practices at the installation shall be carried out and submitted to the Agency. The review shall identify measures to reduce emissions to all media, the likely cost of such measures and a proposed timetable for their implementation.

5.2.2.2 The improvement plan shall be implemented subject to such amendments or additions as notified by the Agency in writing.

5.2.2.3 The improvement plan shall be submitted within 12 months of the issue of the permit.

#### **How can I meet the requirements of these conditions?**

The review of the housing should take into account all the appropriate measures for design and management given above in section 5.2.1 and also the issues below. The cost-effectiveness of any measures introduced should be considered. Minimum standards for welfare must be complied with in the design and operation of the housing on the installation.

#### **Management practices**

Emissions from pig housing are affected by the factors such as ventilation, temperature and management of surfaces. Changes to management of these should only be introduced where such changes will not affect pig health and welfare.

### ***Ventilation***

Ventilation should meet pig health and welfare needs for the age and number of pigs. The target rates for different weather conditions should be calculated in conjunction with your equipment supplier or pig adviser.

### ***Temperature***

Temperature should meet pig health and welfare needs for the age and number of pigs. Liveweight, group size, floor type, air speed and feed intake can markedly affect temperature requirements and should be considered when determining the minimum temperature appropriate.

Slatted floors and restricted feed levels generally require increased temperatures whereas straw bedding, high feed levels and higher body weights generally reduce temperature requirements.

### **Structural improvements**

Whether structures or buildings are replaced or modified will be a decision for you in consultation with the Environment Agency, depending on local needs for emission reduction.

Retro-fitting new structures to existing buildings needs to be carefully considered and costed. Research suggests that it may be more cost effective to replace buildings or structures. Any replacements should give equivalent emission reduction to those techniques outlined in the conditions for new housing, and should be planned to fit the business cycle of the installation.

### **Where can I get further information?**

You should discuss changes to management with your pig advisor.

The following documents give advice on the management of pigs:

- [Code of Recommendations for the Welfare of Livestock: Pigs](#), Defra 2003 PB 7050.
- EU Directive 91/630/EEC Pig Welfare Directive which has been implemented in England through the [Welfare of Farmed Animals \(England\) \(Amendment\) Regulations 2003](#) S.I. 2003 No. 299. This came into force on 14 February 2003.
- [Environmental factors in pig production](#). Description of potential emissions, causes, abatement and legislation. BPEX/MLC May 1999.
- [Environmental Management for Healthy Pig Production](#), BPEX/MLC.

## 5.3 Slurry and manure storage

Manure and slurry are defined in the information box in section vii.i.

### 5.3.1 Slurry storage

5.3.1.1 The operator shall take appropriate measures in the design, construction and management of slurry storage systems to prevent, or where that is not possible, to minimise the emissions from those systems.

5.3.1.2 Proposals for replacing or covering existing uncovered slurry stores and lagoons shall be submitted to the Agency. The proposals shall include a timetable for the replacement and refurbishment work.

The proposals shall be implemented subject to such amendments or additions as notified by the Agency in writing.

The proposals shall be submitted within 6 months of the issue of the permit.

#### How can I meet the requirements of these conditions?

The following are the appropriate measures that you should take to comply with the conditions. We would expect to see and be able to check these measures when inspecting the installation.

The proposals for replacing or covering existing slurry stores and lagoons should ensure that the standards for slurry storage specified in the appropriate measures are met.

There is a legal requirement to notify the Environment Agency at least 14 days before a new or altered structure for slurry storage is brought into use.

#### **Appropriate measures for infrastructure design and construction**

- All new and substantially reconstructed or substantially enlarged slurry storage systems, must:
  - conform with the technical measures detailed in the Control of Pollution (Silage, Slurry and Agricultural Fuel Oil) Regulations 1991 (amended 1997);
  - be covered.
- Acceptable slurry storage facilities must have the following features:
  - Base of the storage tank, effluent tank, and all parts of the drains and reception pit to be impermeable.
  - Base and walls of storage tank, reception pit and drains should be protected against corrosion as described in BS 5502, Part 50.
  - Slurry storage tank and reception pit designed to BS 5502, Part 50.
  - Reception pit and associated channels normally to hold at least two days slurry production, including rainwater.
  - Minimum slurry storage tank capacity to be normally four months production, including allowance for rainwater. The slurry storage tank must be designed to have a minimum 300mm freeboard or 750mm for earth banked stores.
  - Minimum 750mm freeboard to be maintained at all times in earth banked stores.

- No part of a structure should be within 10m of a watercourse unless the written agreement of the Environment Agency is obtained beforehand.
- Tank, channels and pit to be designed for 20 years' life with routine maintenance.
- Two valves in series on any outlet pipe to be locked shut when not in use. (Ensure adequate spacing between the valves).
- Where walls of the slurry store are not impermeable, perimeter drains and effluent tank must be provided. The base must extend beyond the walls.
- Slurry storage covers should comprise a rigid cover (or other effective technique) to a steel or concrete tank.
- New earth banked lagoons should not be constructed unless an effective covering method can be demonstrated.
- Wash water tanks do not need to be fully covered if the wash water has a dry matter content of less than 1%.
- The options for covering existing slurry stores are:
  - to fit a rigid cover to a steel or concrete tank, or
  - to use a floating cover.
- Materials, such as straw or peat will sink and do not reduce emissions effectively and are not acceptable as cover materials. They can also block pipes and pumps.

#### **Appropriate measures for management**

- Management systems should be in place to ensure regular inspection of the store (see condition 1.1.1).
- For existing slurry storage, which do not have a rigid cover, the following measures apply:
  - where floating covers are used, disturbance to the surface must be minimised;
  - slurry stirring should be minimised - although it is recognised that slurry mixing may be necessary to produce a suitable material for land application;
  - slurry should be introduced below the surface to reduce emissions of ammonia and odour.

#### **Where can I get further information?**

Advice on constructing slurry stores is in Chapter 4 of the [Defra Code of Good Agricultural Practice for the Protection of Water](#) (the Water Code).

You can obtain the following [Construction Guidance Notes](#) from Acorus (formerly published by ADAS):

- CGN 100 Organising contracts for farm waste structures (manure and slurry);
- CGN 001 Above-ground circular concrete and rectangular weeping-wall slurry stores;
- CGN 002 Earth-banked slurry stores;
- CGN 003 In-situ concrete slurry stores;
- CGN 004 Above-ground circular steel slurry stores;
- CGN 010 Sluice valves on steel and concrete circular above-ground slurry stores;
- CGN 011 The use of covers on circular steel and concrete slurry stores.

CIRIA report 126 '[Farm waste storage - guidelines for construction](#)' details design and construction guidance for storage facilities. (This can be purchased from CIRIA or obtained through a library - ISBN: 0-86017-352-6).

### 5.3.2 Manure storage

5.3.2.1 The operator shall take appropriate measures in the design, construction and management of manure storage systems to prevent, or where that is not possible, to minimise the emissions from those systems.

5.3.2.2 Proposals for installing an impermeable base with effluent containment for manure stores shall be submitted to the Agency. The proposals shall include a timetable for the construction work.

The proposals shall be implemented subject to such amendments or additions as notified by the Agency in writing.

The proposals shall be submitted within 6 months of the issue of the permit.

#### **How can I meet the requirements of these conditions?**

The following are the appropriate measures that you should take to comply with the conditions. We would expect to see and be able to check these measures when inspecting the installation.

The proposals for installing an impermeable base with effluent containment for manure stores should ensure that the standards for manure storage specified in the appropriate measures are met.

#### **Appropriate measures for infrastructure design and construction**

##### ***Yard storage***

- Where manure is stored in the yard all new manure storage areas should:
  - have an impermeable base;
  - provide a collection and containment system for liquid run-off (effluent– defined as slurry in SSAFO) which meets the requirements of the Control of Pollution (Silage, Slurry and Agricultural Fuel Oil) Regulations 1991 (amended 1997).
- Contaminated run-off can be reduced by providing a roof or cover.

##### ***Field storage***

- You should not site field heaps:
  - over field drains;
  - within 10m of a watercourse (or a greater distance if there is a risk of effluent run-off into a watercourse);
  - within 50m of a spring, well or borehole that supplies water for human consumption, or is to be used in farm dairies;
  - where they would cause odour problems for nearby residents.

#### **Appropriate measures for management**

- Maintain effluent channels and collection tanks to avoid blockage.

- Effluent collection tanks should be checked regularly and emptied when necessary so that they do not overflow. The effluent should either be spread to agricultural land in accordance with the manure management plan or disposed of off-site.
- Manure can be stored temporarily in a field for a maximum of 12 months prior to disposal.
- Contaminated run-off and ammonia emissions can be reduced by covering manure with sheeting.

Field heaps may need to be re-sited if there is a risk of pollution or of odour nuisance if the heap is located within 400m of residences.

**Where can I get further information?**

Advice on constructing manure stores is in Chapter 6 of the [Defra Code of Good Agricultural Practice for the Protection of Water](#) (the Water Code).

## 6. Poultry production

This chapter contains the conditions for the processes that are specific to poultry production. You do not need to read this section or comply with these conditions if you do not produce poultry.

### 6.1 Selection and use of poultry feed

- 6.1.1 The operator shall take appropriate measures to provide a diet which minimises the excretion of
- nitrogen; and
  - phosphorus.

#### How can I meet the requirements of this condition?

The aim of the condition is to optimise protein use so that nitrogen excretion is minimised. The nitrogen excreted as a result of excess protein contributes to ammonia emissions to air and to nitrogen rich manure or slurry. The excretion of phosphorus should also be minimised.

**You should discuss the formulation of the diet with a nutritional advisor or feed supplier to ensure that the minimum dietary requirements of the birds are being met.**

As birds age their protein requirement per kg of live weight changes. Where only one diet is fed young birds are under-supplied with protein and lean growth is not maximised, and older birds may be oversupplied with protein and expend energy in excreting it.

The timing of the change from one diet to the next will differ according to the genetics of the stock and management on the installation.

#### Appropriate measures

The following are the appropriate measures that you should take to comply with the condition. For **existing installations** these appropriate measures should be in place no later than **twelve months** from the issue of the permit and represent what we would expect to find when inspecting the installation.

#### **Nitrogen**

You should feed a reducing protein diet over the growing period and laying cycle based on the birds needs. The use of a sequential feeding regime, with reducing levels of protein (measured by crude protein and/or essential and non-essential amino acids) will reduce the amount of nitrogen excreted. Lower levels of excreted nitrogen reduce ammonia emissions to air and levels of nitrogen in the litter.

The whole wheat feeding system, where a quantity of wheat is mixed with compound feed, is permitted and meets the requirements of this condition, provided that the birds are fed diets with a reducing protein content over the growing period. This feeding system in effect provides a number of diets as the inclusion of wheat is increased.

- Broilers and broiler breeders should be a fed a minimum of three diets.
- Commercial laying hens should be fed a minimum of three diets over the cycle.
- For replacement layer pullets and rearing of breeding stock, a minimum of two diets should be used between hatching and point of lay for optimum feed utilisation.

- For turkeys, the crude protein levels should decrease with age. Young hens reared for the small, oven-ready market shall be fed a minimum of two diets. Other turkeys reared for less than 16 weeks should be fed a minimum of three diets. Turkeys reared in excess of 16 weeks should be fed a minimum of four diets.
- Ducks should be fed a minimum of two diets.

### ***Phosphorus***

Phosphorus levels in rations for poultry should be reduced over their rearing and production cycle. Lower phosphorus levels in diets fed to the bird will reduce phosphorus excretion and so reduce phosphorus levels in manure/litter.

- The use of phytase enzyme may be considered as a means to increase availability of phosphorus from vegetable sources and so reduce total phosphorus levels in the diet.
- There are currently no enzyme products licensed for use in duck feeds in Europe.
- Where possible the amount of total and available phosphorus in the diet should be recorded to assist in assessing phosphorus content of litter and manure.
- A minimum phosphorus content in litter and manure may be specified in contracts for litter-burning power stations.

### ***Buildings and associated infrastructure***

- All buildings and associated infrastructure i.e. feed storage bins, should be specifically designed to accommodate the required feeding regime.

## **6.2 Housing design and operation**

### **6.2.1 New poultry housing design and operation**

6.2.1.1 The operator shall take appropriate measures in the design and management of housing to minimise the emissions from those systems.

#### **How can I meet the requirements of this condition?**

The aim of the condition is to ensure that housing, litter and slurry systems are designed and managed to minimise releases, particularly of ammonia and odour. Minimum standards for welfare must be complied with in the design and operation of the housing on the installation.

The following are the appropriate measures that you should take to comply with the condition. They are divided into appropriate measures for design and management. We would expect to see that the relevant measures have been taken when inspecting the installation.

#### **Appropriate measures for design**

You should ensure that, **from the date of permit** issue, any new poultry housing, either replacement housing or on an expanded installation, is designed in accordance with this condition. Other techniques are not excluded, but you will need to demonstrate that they qualify as BAT.

#### ***Drinkers and troughs***

- Drinkers and troughs should be designed to prevent leakage.

#### ***Housing***

- Housing should be well insulated and have a damp proof course;

- Houses should be insulated to a U-value of  $0.4 \text{ W/m}^2/\text{°C}$  or better;
- Where poultry rearing systems use housing with open sides, insulation is not required.

### ***Cage systems***

Housing shall be designed with:

- deep pit with ventilated manure store; or
- manure removal, at least twice a week, by way of manure belts to covered storage; or
- vertical tiered cages with manure belt with forced air drying, where the manure is removed at least once a week to a covered storage; or
- vertical tiered cages with manure belt with whisk forced air drying where manure is removed at least once a week to a covered storage; or
- vertical tiered cages with manure belt with improved forced air drying where the manure is removed from the house at least once a week to covered storage; or
- vertical tiered cages with manure belt with drying tunnel over cages, after 24-36 hours, the manure is removed to covered storage; or
- other techniques that provide equivalent or better emission minimisation.

### ***Barn and free-range systems***

Housing shall be designed with:

- litter system with forced air drying; or
- litter system with perforated floor and forced air drying; or
- an aviary system with or without range and or outside scratching area; or
- other techniques that provide equivalent or better emission minimisation.

### ***Broiler, broiler breeders, replacement pullet and turkey systems***

Housing shall be designed with:

- a naturally ventilated house with a fully littered floor and equipped with non-leaking drinking systems; or
- a fan ventilated house with a fully littered floor and equipped with non-leaking drinking systems; or
- other techniques that provide equivalent or better emission minimisation.
- Open turkey houses should be aligned at right angles to the prevailing wind direction and located to ensure exposure to natural airflow.
- These systems also apply to free-range poultry reared for meat.

### ***Duck systems***

Housing shall be designed with an unrestricted naturally ventilated house or a well-insulated fan ventilated house with:

- a partly-slatted floor with impermeable drainage channels and effluent storage area; or
- a fully-slatted floor with impermeable drainage channels and effluent storage area; or
- a fully littered floor with a water system positioned above a gully and covered drainage channels and effluent storage areas; or

- other techniques that provide equivalent or better emission minimisation.

### **Appropriate measures for management**

#### ***Litter and manure***

It should be noted that there are additives on the market that claim to reduce emissions to air (ammonia, odour). The efficacy of some products has been found to be poor, and some may not be economically worthwhile.

- Litter should be kept loose and friable and its quality should be inspected to ensure it does not become excessively wet or dry. Any changes in quality should be investigated, and steps taken to rectify the problem.
- Solutions may involve the addition of extra material or provision of heating to the problem area. Capping or wet litter should be avoided and may be due to birds drinking and excreting more due to illness, high temperatures, a feed problem or increased humidity.
- The drinker system should be considered. The use of nipple drinkers with drip cups will minimise water spillage. Where drip cups are not used, or other drinkers are provided, water pressure should be checked frequently, and wet litter around drinkers should be addressed.
- You should manage the floor of the house to minimise seepage of water either from the ground or entry of rainfall. An impermeable floor and damp-proof course will give the best protection. Where this is not present, a mixture of materials or thicker layers may address wet litter problems.
- In layer housing using manure belts, increasing the frequency of belt cleaning may reduce emissions.
- Removal of litter from the turkey house at intervals during the fattening period reduces the ammonia emissions, as the temperature of the litter and droppings does not increase.
- Mixing of manure during the turkey fattening period gives maximum uptake of ammonia by sawdust/shavings/chopped straw.

#### ***Temperature***

- Temperature should meet health and welfare needs for the age and number of birds.
- Extremes of temperature should be avoided and draughts should be minimised.
- Where artificial heating is provided, controls should be used to match heating needs to ventilation needs so that heat is not wasted, by being drawn out of the building.
- Birds should not be subjected to conditions, which cause either panting due to overheating or prolonged huddling and feather ruffling due to under-heating. Every effort should be made to avoid creating conditions, which will lead to chilling, huddling and subsequent smothering.
- Insulating housing may provide a more long-term option and will reduce energy consumption.

#### ***Ventilation***

- Ventilation should match the health and welfare needs for the age and number of birds. The target rates for different weather conditions should be calculated in conjunction with an equipment supplier or poultry adviser. Air speeds across the house should not be largely different from one area to another, and housing should be free from draughts.

- Ventilation rates and house conditions should at all times be adequate to provide sufficient fresh air for the birds. In particular, accumulations of ammonia, hydrogen sulphide, carbon dioxide, carbon monoxide and dust should be avoided.
- In deep-pit layer housing, air currents should be maintained so that air is drawn over the manure to dry it. Rain should be prevented from entering the manure storage area.
- Belt cleaning systems should be designed and operated to optimise air flow and to maximise drying on the belt.

### **General management**

- Floors and walls should be kept clean.
- Cracks and damaged areas of floors and walls should be repaired.
- For free-range poultry, the areas around pop-holes should be protected to prevent rain from entering housing. You should manage the ground around pop-holes to prevent capping or erosion of the surface.

### **Where can I get further information?**

Examples and descriptions of housing designs which meet the appropriate measures are described in Appendix 3. These examples are taken from the BAT Reference Document (BREF) for Intensive Rearing of Poultry and Pigs.

The following documents give advice on the management of poultry:

- [Poultry Litter Management](#), Defra PB1739;
- [Heat stress in poultry – solving the problem](#), Defra PB10543;
- [Code of Recommendations for the Welfare of Livestock: Laying hens](#) Defra 2002 PB 7274;
- [Code of Recommendations for the Welfare of Livestock: Turkeys](#), Defra;
- [Code of Recommendations for the Welfare of Livestock: Meat chickens and breeding chickens](#). Defra 2002 PB 7275;
- [Code of Recommendations for the Welfare of Livestock: Ducks](#), Defra.

## **6.2.2 Existing poultry housing**

6.2.2.1 A review of existing poultry housing and management practices at the installation shall be carried out. The review shall identify measures to reduce emissions to all media, the likely cost of such measures and a proposed timetable for their implementation; and shall be submitted to the Agency within 12 months of the issue of the permit.

6.2.2.2 The improvement plan shall be implemented subject to such amendments or additions as notified by the Agency in writing.

6.2.2.3 The improvement plan shall be submitted within 12 months of the issue of the permit.

### **How can I meet the requirements of these conditions?**

The review of the housing should take into account all the design and management appropriate measures given above in section 6.2.1 and also the issues below. The cost-effectiveness of any measures introduced should be considered. Minimum standards for welfare must be complied with in the design and operation of the housing on the installation.

#### **Management practices**

Emissions from poultry housing are affected by factors such as ventilation, temperature and management. Changes to management of these should only be introduced where such changes will not adversely affect poultry health and welfare.

#### ***Ventilation***

Ventilation should meet poultry health and welfare needs for the age and number of birds. The target rates for different weather conditions should be calculated in conjunction with your equipment supplier or poultry adviser.

#### ***Temperature***

Temperature should meet poultry health and welfare needs for the age and number of poultry. Age, flock size, floor type, air speed, feed and water intake can markedly affect temperature requirements and should be considered when determining the minimum temperature appropriate.

#### **Structural improvements**

Whether structures or buildings are replaced or modified will be a decision for you in consultation with the Environment Agency, depending on local needs for emission reduction.

Retro-fitting new structures to existing buildings needs to be carefully considered and costed. Research suggests that it may be more cost effective to replace buildings or structures. Any replacements should give equivalent emission reduction to those techniques outlined in the conditions for new housing, and should be planned to fit the business cycle of the installation.

### **Where can I get further information?**

You should discuss changes to management with your poultry advisor.

The following documents give advice on the management of poultry:

- [Poultry Litter Management](#), Defra PB1739;
- [Heat stress in poultry – solving the problem](#), Defra PB10543;
- [Code of Recommendations for the Welfare of Livestock: Laying hens](#) Defra 2002 PB 7274;
- [Code of Recommendations for the Welfare of Livestock: Turkeys](#), Defra;
- [Code of Recommendations for the Welfare of Livestock: Meat chickens and breeding chickens](#). Defra 2002 PB 7275;
- [Code of Recommendations for the Welfare of Livestock: Ducks](#), Defra.

## 6.3 Slurry and manure storage

Manure and slurry are defined in the information box in section vii.i.

### 6.3.1 Slurry storage (including duck effluent and wash water)

6.3.1.1 The operator shall take appropriate measures in the design, construction and operation of slurry storage systems to prevent, or where that is not possible, to minimise the emissions from those systems.

6.3.1.2 Proposals for replacing or covering existing uncovered slurry stores and lagoons shall be submitted to the Agency. The proposals shall include a timetable for the replacement and refurbishment work.

The proposals shall be implemented subject to such amendments or additions as notified by the Agency in writing.

The proposals shall be submitted within 6 months of the issue of the permit.

#### How can I meet the requirements of these conditions?

The following are the appropriate measures that you should take to comply with the conditions. We would expect to see and be able to check these measures when inspecting the installation.

The proposals for replacing or covering existing slurry stores and lagoons should ensure that the standards for slurry storage specified in the appropriate measures are met.

There is a legal requirement to notify the Environment Agency at least 14 days before a new or altered structure for slurry storage is brought into use.

#### **Appropriate measures for infrastructure design and construction**

- All new and substantially reconstructed or substantially enlarged slurry storage systems, must:
  - conform with the technical measures detailed in the Control of Pollution (Silage, Slurry and Agricultural Fuel Oil) Regulations 1991 (amended 1997); and
  - be covered.
- Acceptable slurry storage facilities must have the following features:
  - Base of the storage tank, effluent tank, and all parts of the drains and reception pit to be impermeable.
  - Base and walls of storage tank, reception pit and drains should be protected against corrosion as described in BS 5502, Part 50.
  - Slurry storage tank and reception pit designed to BS 5502, Part 50.
  - Reception pit and associated channels normally to hold at least two days slurry production, including rainfall.
  - Minimum slurry storage tank capacity to be normally four months production, including allowance for rainwater. The slurry storage tank must be designed to have a minimum 300mm freeboard or 750mm for earth banked stores.
  - Minimum 750mm freeboard to be maintained at all times in earth banked stores.

- No part of a structure should be within 10m of a watercourse unless the written agreement of the Environment Agency is obtained beforehand.
- Tank, channels and pit to be designed for 20 years' life with routine maintenance.
- Two valves in series on any outlet pipe to be locked shut when not in use. (Ensure adequate spacing between the valves).
- Where walls of the slurry store are not impermeable, perimeter drains and effluent tank must be provided. The base must extend beyond the walls.
- Slurry storage covers should comprise a rigid cover to a steel or concrete tank.
- New earth banked lagoons should not be constructed unless an effective covering method can be demonstrated.
- Wash water tanks do not need to be fully covered if the wash water has a dry matter content of less than 1%.
- The options for covering existing slurry stores are:
  - to fit a rigid cover to a steel or concrete tank, or
  - to use a floating cover.
- Materials, such as straw or peat will sink and do not reduce emissions effectively and are not acceptable as cover materials. They can also block pipes and pumps.

#### **Appropriate measures for operations**

- Management systems should be in place to ensure regular inspection of the store (see condition 1.1.1).
- For existing slurry storage, which do not have a rigid cover, the following measures apply:
  - Where floating covers are used, disturbance to the surface must be minimised.
  - Slurry stirring should be minimised - although it is recognised that slurry mixing may be necessary to produce a suitable material for land application.
  - Slurry should be introduced below the surface to reduce emissions of ammonia and odour.

#### **Where can I get further information?**

Advice on constructing slurry stores is in Chapter 4 of the [Defra Code of Good Agricultural Practice for the Protection of Water](#) (the Water Code).

You can obtain the following [Construction Guidance Notes](#) from Acorus (formerly published by ADAS):

- CGN 100 Organising contracts for farm waste structures (manure and slurry);
- CGN 001 Above-ground circular concrete and rectangular weeping-wall slurry stores;
- CGN 002 Earth-banked slurry stores;
- CGN 003 In-situ concrete slurry stores;
- CGN 004 Above-ground circular steel slurry stores;
- CGN 010 Sluice valves on steel and concrete circular above-ground slurry stores;
- CGN 011 The use of covers on circular steel and concrete slurry stores.

CIRIA report 126 '[Farm waste storage - guidelines for construction](#)' details design and construction guidance for storage facilities. (This can be purchased from CIRIA or obtained through a library - ISBN: 0-86017-352-6).

### 6.3.2 Manure storage

6.3.2.1 The operator shall take appropriate measures in the design, construction and operation of manure storage systems to prevent, or where that is not possible, to minimise the emissions from those systems.

6.3.2.2 Proposals for installing an impermeable base with effluent containment for manure stores shall be submitted to the Agency. The proposals shall include a timetable for the construction work.

The proposals shall be implemented subject to such amendments or additions as notified by the Agency in writing.

6.3.2.3 The proposals shall be submitted within 6 months of the issue of the permit.

#### How can I meet the requirements of these conditions?

The following are the appropriate measures that you should take to comply with the conditions. We would expect to see and be able to check these measures when inspecting the installation.

The proposals for installing an impermeable base with effluent containment for manure stores should ensure that the standards for manure storage specified in the appropriate measures are met.

#### **Appropriate measures for infrastructure design and construction**

##### ***Yard storage***

- Where manure is stored in the yard all new manure storage areas should:
  - have an impermeable base;
  - provide a collection and containment system for liquid run-off (effluent– defined as slurry in SSAFO) which meets the requirements of the Control of Pollution (Silage, Slurry and Agricultural Fuel Oil) Regulations 1991 (amended 1997);
- Contaminated run-off can be reduced by providing a roof or cover.

##### ***Field storage***

- You should not site field heaps:
  - over field drains;
  - within 10m of a watercourse (or a greater distance if there is a risk of effluent run-off into a watercourse);
  - within 50m of a spring, well or borehole that supplies water for human consumption, or is to be used in farm dairies;
  - where they would cause odour problems for nearby residents.

Field storage should be avoided, as there is currently no method of adequately covering such a storage heap. Where no alternative to field storage is available, litter and manure should be stored in a densely packed heap with an "A" shaped profile.

**Appropriate measures for operations**

- Maintain effluent channels and collection tanks to avoid blockage.
- Effluent collection tanks should be checked regularly and emptied when necessary so that they do not overflow. The effluent should either be spread to agricultural land in accordance with the manure management plan or disposed of off-site.
- Manure can be stored temporarily in a field for a maximum of 12 months prior to disposal.
  
- Contaminated run-off and ammonia emissions can be reduced by:
  - covering manure with sheeting
  - maintaining the dry matter content above 60%.

Field heaps may need to be re-sited if there is a risk of pollution or of odour nuisance if the heap is located within 400m of residences.

**Where can I get further information?**

Advice on constructing manure stores is in Chapter 6 of the [Defra Code of Good Agricultural Practice for the Protection of Water](#) (the Water Code).

## 7. Slurry spreading and manure management planning

This chapter contains the conditions for the slurry spreading and manure management processes for pig rearing and poultry production.

### 7.1 Off-site activity

7.1.1 The operator shall take appropriate measures in off-site disposal or recovery of solid manure or slurry to prevent, or where this is not possible, to minimise pollution.

#### How can I meet the requirements of this condition?

The following are the appropriate measures that you should take to comply with the condition. We would expect to see and be able to check these measures when inspecting the installation.

- You should maintain written evidence of the arrangements in place when you export slurry and manure such as:
  - records of the quantities and the date of transfer for example, to power station or biogas plant for recovery; waste water treatment plant for disposal; or third party for spreading to land;
  - the names and addresses and land acreage available where manures and slurries are exported for spreading to land.
- Where a 'manure agent' or other third party accepts liability for removing manure or slurry from the installation, you should provide acceptable confirmation that:
  - as a minimum, the third party will ensure that the manure is spread to land in accordance with the Codes of Good Agricultural Practice for soil, air and water; or
  - that the spreading will be in accordance with a manure management plan for the receiving land.

You should have contingency arrangements in place should there be an emergency or the land becomes unavailable for spreading, such as alternative land areas to be used or for alternative storage to be provided (this could be part of the accident management plan).

#### Where can I get further information?

Advice on slurry and manure spreading practices is in the [Defra Codes of Good Agricultural Practice](#) for the protection of water, soil and air.

See 7.2.1 for advice on manure management planning.

### 7.2 On-site activity

The controls on land spreading in conditions 7.2.1.1 to 7.2.4.1 apply where manure is spread on your site. This would apply to either:

- the operator or employees spreading on the site; or
- a contractor spreading on the site.

## 7.2.1 Manure management planning

7.2.1.1 The operator shall:

- (a) maintain and implement a manure management plan;
- (b) review and record at least every 4 years whether changes to the plan should be made;
- (c) make any appropriate changes to the plan identified by a review.

### How can I meet the requirements of this condition?

#### Implement the manure management plan

Where manure or slurry is applied to land in a Nitrate Vulnerable Zone, the mandatory conditions of the action programme will apply.

Where the installation is to be used for the spreading of slurry, manure or litter, a risk-based approach, detailing which land is suitable for spreading and when, will be required.

The plan should account for any manures brought onto the installation, including sewage sludge and other organic wastes.

#### Record keeping

You need to keep records to demonstrate that you have implemented the manure management plan. This applies whether you, your employees or a contractor conducts the spreading. This should include:

- the nutrient content of the manure and slurry applied to each field;
- the weight of manure and slurry applied to each field.

Where you keep such records already for other purposes, such as for NVZ requirements or a farm assurance scheme, this format will usually be sufficient.

Where possible, a weighbridge should be used for initial manure management planning, and then if either the spreading operator or machinery are changed, to allow a more accurate estimate of the quantity of manure spread.

#### Review the manure management plan

You should review your manure management plan at least every four years, and implement any required changes.

#### Where can I get further information?

Guidance on the content and design of manure management plans is available in the following documents:

- [Manure Management Planning for IPPC Installations](#) - Environment Agency guide;
- Environment Agency [Factsheet 5](#) – producing a manure management plan;
- [Manure Management Plan: a step-by-step guide for farmers](#) – Defra guidance;
- the three 'Managing Livestock Manures' booklets available from the [Defra website](#) or from ADAS Gleadthorpe Research Centre (Tel: 01623 844331):
  - Booklet 1 - Making better use of livestock manures on arable land;
  - Booklet 2 - Making better use of livestock manures on grassland;
  - Booklet 3 - Spreading systems for slurries and solid manures.

## 7.2.2 Nutrient status of soil, manure and slurry

7.2.2.1 The nutrient status of the soil and of manures and slurries shall be analysed for the parameters and at no less than the frequency specified by the Agency.

7.2.2.2 The nutrient status of the soil, manures and slurry shall be reviewed at least every year.

7.2.2.3 Records of nutrient sampling and reviews shall be maintained.

### How can I meet the requirements of these conditions?

- Slurry and manures should be analysed twice yearly, or once per production cycle where that cycle exceeds six months. Analysis should include:
  - total nitrogen
  - available nitrogen
  - total phosphorus
  - available phosphorus
- Soil should be analysed for phosphorus as a minimum, every four years.

The requirements for soil and manure analysis may change in light of the information gathered, for example, analysis may be reduced if consistent results are seen or increased if highly variable results are found.

### Where can I get further information?

A protocol for sampling slurry and solid manure for analysis is provided in Appendix 1.

Further advice is available in the following documents:

- [Defra Code of Good Agricultural Practice for the Protection of Water](#);
- Defra document, [Manure Planning in NVZs](#);
- the three 'Managing Livestock Manures' booklets available from the [Defra website](#) or from ADAS Gleadthorpe Research Centre (Tel: 01623 844331):
  - Booklet 1 - Making better use of livestock manures on arable land;
  - Booklet 2 - Making better use of livestock manures on grassland;
  - Booklet 3 - Spreading systems for slurries and solid manures.
- 'Fertiliser Recommendations for Agricultural and Horticultural Crops' RB209 – this can be downloaded in sections from the [Defra website](#) or obtained from the [Stationary Office](#).

You can also discuss sampling and analysis with your crop consultant/agronomist.

## 7.2.3 Spreading of manure and slurry

### Spreading to minimise emissions to air

7.2.3.1 The operator shall take appropriate measures when spreading manure or slurry to land to prevent, or where this is not possible to minimise the emissions to air.

#### How can I meet the requirements of this condition?

The following are the appropriate measures that you should take to comply with the condition. We would expect to see and be able to check these measures when inspecting the installation.

#### **Appropriate measures for solid manure**

- Applications of solid manure to un-cropped land or bare soil should be incorporated within 24 hours, unless such applications are used to control wind erosion on susceptible soils.
- Incorporation should be achieved by ploughing, discing or using a rotary cultivator.
- Solid manure does not need to be incorporated if it is applied to grassland or other established crops.

#### **Appropriate measures for slurry (includes duck effluent and wash water)**

Slurry should be applied to land using only the following methods:

- An injector or band-spreader.
- Any type of equipment with splash plates, provided slurry is incorporated into the soil within 6 hours of application and provided such equipment is operated to avoid slurry atomisation and drift i.e. operated at low pressure to create large droplets.
- Irrigation – where this method is used the slurry should be applied to a growing crop. The equipment should be operated to provide a low spreading trajectory (operated at low pressure to create large droplets).
  - Where dilute pig slurry (less than 2% dry matter) is applied using irrigation then the requirement for this to be to a growing crop does not apply. This is based on Defra funded research (WA0715) which indicates that ammonia emissions from dilute pig slurry (1.7% dry matter) are not significant.
  - Incorporation is unnecessary for wash water with less than 1% dry matter.

#### Where can I get further information?

Further information is available in the three 'Managing Livestock Manures' booklets available from the [Defra website](#) or from ADAS Gleadthorpe Research Centre (Tel: 01623 844331):

- Booklet 1 - Making better use of livestock manures on arable land;
- Booklet 2 - Making better use of livestock manures on grassland;
- Booklet 3 - Spreading systems for slurries and solid manures.

The [Defra Code of Good Agricultural Practice for the Protection of Air](#) contains useful information.

The Defra funded research project 'Ammonia emissions from irrigation of dilute pig slurry', R&D Report WA0715 is available by contacting Defra.

## Spreading to minimise pollution of water

7.2.3.2 The operator shall take appropriate measures when spreading manure or slurry to land to prevent, or where this is not possible to minimise pollution of water.

### How can I meet the requirements of this condition?

The following are the appropriate measures that you should take to comply with the condition. We would expect to see and be able to check these measures when inspecting the installation.

- You should apply manure and slurry to land according to your manure management plan. This plan will identify the areas that are not suitable for spreading.
- You should not apply manure and slurry when soil is:
  - waterlogged
  - flooded
  - frozen hard
  - snow covered
  - cracked down to field drains or back-fill
- You should not apply manure and slurry to steeply sloping fields. Slopes are complex features of the landscape and it is not practicable to define critical angles of slope. As a guide, steep slopes are usually over 11° (around 1 in 8) and moderate slopes 8 - 11° (around 1 in 12 to 1 in 8).
- You should always take care when spreading, regardless of the nature of the slope, as run-off can occur from land that is almost flat. The risk of surface runoff increases with the steepness of the slope.
- Restricting application rates and consequently the loading rate of total solids reduces the risk of run-off and the possibility of carrying organic matter, nitrate, phosphorus and ammonium N into watercourses.
- Applications of organic manures should be made to maximise the availability of nutrient for the crop and minimise the risk of run-off to watercourses and pollution of groundwater.
- Further restrictions may apply in Nitrate Vulnerable Zones.

### Where can I get further information?

Further information is available in the three 'Managing Livestock Manures' booklets available from the [Defra website](#) or from ADAS Gleadthorpe Research Centre (Tel: 01623 844331):

- Booklet 1 - Making better use of livestock manures on arable land;
- Booklet 2 - Making better use of livestock manures on grassland;
- Booklet 3 - Spreading systems for slurries and solid manures.

The [Defra Code of Good Agricultural Practice for the Protection of Water](#) contains useful information.

## 7.2.4 Minimising pollution from, and accumulation of, soil nutrients

### Nitrogen

7.2.4.1 Application rates of organic manures and slurries, including sewage sludges and other organic wastes, shall not exceed 250 kilograms/hectare of total organic nitrogen in any 12 month period.

#### How can I meet the requirements of this condition?

The following are the appropriate measures that you should take to comply with the condition. We would expect to see and be able to check these measures when inspecting the installation.

- You must ensure that organic manure is not applied to any field at a rate which would result in the total nitrogen supplied in the manure exceeding 250kg/ha in any 12 month period. This is equivalent to the field based limit for the Action Programme for Nitrate Vulnerable Zones.
- You are required to analyse the nutrient content of your manures under condition 7.2.2.1. The total and available nitrogen (N) content of your manures will be available from this analysis.
- For new installations analysis of N content may be estimated from standard figures available in the Defra document 'Manure Planning in NVZs'.
- Duck manure may be treated as farmyard manure rather than poultry manure where a low level (less than 30%) of available N can be demonstrated by analysis.

Tighter limits may apply in Nitrate Vulnerable Zones.

Enforcement of this condition will take into account local weather, cropping and soil conditions.

#### Where can I get further information?

Standard figures for N available to crops from manure and slurry are in the Defra guide 'Manure Planning in NVZs'. Further advice on the field based limit is in the Defra guide 'Guidelines for farmers in NVZs'. Both of these documents can be downloaded via the [Nitrates pages](#) of the Defra website.

General advice on spreading to minimise pollution from nitrogen can be found in the Defra [Code of Good Agricultural Practice for the Protection of Water](#).

### Phosphorus

A condition for phosphorus management is under development (see Appendix 4 for details).

High levels of phosphorus (P) can accumulate in soils receiving regular large applications of organic manure. This can increase P loss to water.

P from livestock manures can reach surface waters by various routes. The main losses are:

- surface run-off, particularly of recently spread manures;
- erosion of eroded soil particles with a high P content;
- particulate and dissolved P in water flowing to land drains.

You can minimise the risk of P losses by surface water run-off by following your Manure Management Plan.

The amount of P lost will depend on the soil P level. The higher the soil P level, the higher the loss. There is a risk that fields which receive regular applications of livestock manures may accumulate soil P levels which exceed those necessary for crop production.

**Where can I get further information?**

You can get advice on minimising the risk of soil erosion by following the Defra [Code of Good Agricultural Practice for the Protection of Soil](#). The Defra information pack '[Controlling soil erosion](#)' also contains useful information.

## References and contact details

This chapter provides contact details for the organisations referred to in this document. It also summarises the references in this document and other useful information produced by each organisation.

Where a hyperlink (e.g. [www.environment-agency.gov.uk](http://www.environment-agency.gov.uk), or [PPC for pig and poultry farmers](#) [blue text]) is included this indicates a useful webpage or where a document can be downloaded from a website.

### Environment Agency

- Website: [www.environment-agency.gov.uk](http://www.environment-agency.gov.uk)
- Enquiries: 08708 506 506
- Email: [enquiries@environment-agency.gov.uk](mailto:enquiries@environment-agency.gov.uk)
- Head Office Address: Rio House, Waterside Drive, Aztec West, Almondsbury, Bristol BS32 4UD

The following documents can be downloaded from the [PPC for pig and poultry farmers](#) pages (Agriculture > Pig and poultry > PPC for pig and poultry farmers or [http://www.environment-agency.gov.uk/business/444304/1224648/1224695/1116263/?version=1&lang=\\_e](http://www.environment-agency.gov.uk/business/444304/1224648/1224695/1116263/?version=1&lang=_e)):

- Latest version of IPPC Intensive Farming How to Comply – Guidance for intensive pig and poultry farmers
- Odour Management at Intensive Livestock Installations
- Noise Management at Intensive Livestock Installations
- Guidance for Operators on Manure Management Planning for IPPC Installations
- Interpretation of an Installation for the Intensive Farming Sector
- IPPC Intensive Farming Application Site Report Guidance and Template
- Assessment of Environmental Impacts from Intensive Livestock Installations
- Waterwise on the Farm (Environment Agency/NFU/LEAF)
- Guidelines for construction of swales for water quality improvement and flow attenuation of lightly contaminated runoff from poultry farms
- Application Form for a Pig and Poultry Rearing Permit (ILF1)
- Application Form for a Variation to a Pig and Poultry Rearing Permit (ILF2)
- Application Form for Transfer of a Pig and Poultry Rearing Permit (ILF3)
- Application Form for Surrender of a Pig and Poultry Rearing Permit (ILF4)
- Current version of IPPC Pigs and Poultry Annex 1 – supplementary information for the application forms on emission factors and charges
- The series of six factsheets:
  - Factsheet 1 – Integrated Pollution Prevention and Control for farmers
  - Factsheet 2 – producing a site layout plan
  - Factsheet 3 – producing a site drainage plan
  - Factsheet 4 – producing an accident management plan

- Factsheet 5 – producing a manure management plan
- Factsheet 6 – documentation check list

Cross sector or 'horizontal guidance' can be downloaded from the PPC pages (Business and industry > How we regulate your business > Directives > Pollution Prevention and Control > Cross sector technical guidance or [http://www.environment-agency.gov.uk/business/444217/444663/298441/horizontal/?version=1&lang=\\_e](http://www.environment-agency.gov.uk/business/444217/444663/298441/horizontal/?version=1&lang=_e)). This includes:

- [IPPC H3: Part 1 – Regulation and Permitting and Part 2 – Noise Assessment and Control](#);
- [IPPC H4: Horizontal Odour Guidance. Part 1: Regulation and Permitting and Part 2: Assessment and Control](#);
- [IPPC H7 'Guidance on the protection of land under the PPC regime: Application Site Report and Site Protection and Monitoring Programme'](#) and associated templates:
  - [IPPC H7 Reporting Template 2](#) - Template for Design of a Site Protection and Monitoring Programme for Installations Requiring Reference Data to be Collected.
  - [IPPC H7 Reporting Template 3](#) - Template for Design of a Site Protection and Monitoring Programme for Installations, that DO NOT Require Reference Data to be Collected.
- [IPPC H8 'Guidance on the Protection of Land under PPC Regime : Surrender Site Report \(Draft Consultation Version 1\)'](#) and [IPPC H8 Surrender Site Report Template](#).

Other relevant documents:

- Pollution prevention guidance notes including [PPG 21](#) (pollution incident response planning), [Concrete bunds for oil storage tanks](#) and [Masonry bunds for oil storage tanks](#) can be downloaded from: [http://www.environment-agency.gov.uk/business/444251/444731/ppg/?version=1&lang=\\_e](http://www.environment-agency.gov.uk/business/444251/444731/ppg/?version=1&lang=_e).
- [Groundwater Regulations leaflet](#): [http://www.environment-agency.gov.uk/business/444217/444663/955191/?version=1&lang=\\_e](http://www.environment-agency.gov.uk/business/444217/444663/955191/?version=1&lang=_e)
- [Nitrate Vulnerable Zones leaflet](#): <http://publications.environment-agency.gov.uk/pdf/PMHO0603BHFI-e-e.pdf>.

Information and guidance on the Agricultural Waste Regulations can be found on the [Agricultural Waste](#) pages: [http://www.environment-agency.gov.uk/business/444304/1224648/660279/241420/?version=1&lang=\\_e](http://www.environment-agency.gov.uk/business/444304/1224648/660279/241420/?version=1&lang=_e).

'What's in your backyard' (<http://www.environment-agency.gov.uk/maps/>) provides information on:

- groundwater source protection zones
- Pollution Inventory sites (e.g. large industrial sites, large sewage works and other sources of emissions)
- river water quality information
- discharges to sea

This information may be helpful in preparing your application. Groundwater source protection zones can be downloaded free of charge.

## Department for Environment, Food and Rural Affairs (Defra)

- Website: [www.defra.gov.uk](http://www.defra.gov.uk)
- Defra Helpline: 08459 335577
- Helpline email address: [helpline@defra.gsi.gov.uk](mailto:helpline@defra.gsi.gov.uk)
- Defra publications are available from the website, by telephoning 08495 556000 or by writing to Defra Publications, Admail 6000, London, SW1A 2XX

### Useful webpages:

- Pollution Prevention and Control: <http://www.defra.gov.uk/environment/ppc/index.htm>
- Animal By-Products: <http://www.defra.gov.uk/animalh/by-prods/default.htm>
- Agricultural Waste Regulations:  
<http://www.defra.gov.uk/environment/waste/agforum/index.htm>

### References and publications:

- Approved list of disinfectants:  
[http://www.defra.gov.uk/animalh/diseases/control/testing\\_disinfectants.htm](http://www.defra.gov.uk/animalh/diseases/control/testing_disinfectants.htm)
- Waste Minimisation Manual - opportunities for saving money by reducing waste on your farm (PB4819):  
<http://www.defra.gov.uk/environment/waste/topics/agwaste.htm#reducewaste>
- Integrated Pollution Prevention and Control: a Practical Guide:  
<http://www.defra.gov.uk/environment/ppc/ippcguide/index.htm>
- Code of Good Agricultural Practice for the Protection of Water ("The Water Code") (PB0587): <http://www.defra.gov.uk/envirom/cogap/cogap.htm>
- Code of Good Agricultural Practice for the Protection of Soil ("The Soil Code"), (PB0617):  
<http://www.defra.gov.uk/envirom/cogap/cogap.htm>
- Code of Good Agricultural Practice for the Protection of Air ("The Air Code"), (PB0618):  
<http://www.defra.gov.uk/envirom/cogap/cogap.htm>
- Guide to Pesticides (The Blue Book) Electronic Copy:  
<http://www.pesticides.gov.uk/publications.asp?id=499>
- Code of Practice for Using Plant Protection Products (PB11090):  
[http://www.pesticides.gov.uk/safe\\_use.asp?id=64](http://www.pesticides.gov.uk/safe_use.asp?id=64)
- Poultry litter management (PB1739):  
<http://www.defra.gov.uk/animalh/welfare/farmed/meatchks/pb1739/littetoc.htm>
- Heat stress in poultry – solving the problem (PB10543):  
<http://www.defra.gov.uk/animalh/welfare/pdf/hstress05.pdf>
- Code of Recommendations for the Welfare of Livestock: Laying hens (PB7274):  
<http://www.defra.gov.uk/animalh/welfare/farmed/layers/layerscode.pdf>
- Code of Recommendations for the Welfare of Livestock: Turkeys:  
<http://www.defra.gov.uk/animalh/welfare/farmed/otherps/turkeys/pb0077/turkcode.htm>
- Code of Recommendations for the Welfare of Livestock: Meat chickens and breeding chickens (PB7275):  
<http://www.defra.gov.uk/animalh/welfare/farmed/meatchks/meatchkscode.pdf>

- Code of Recommendations for the Welfare of Livestock: Ducks:  
<http://www.defra.gov.uk/animalh/welfare/farmed/othersps/ducks/pb0079/duckcode.htm>
- Code of Recommendations for the Welfare of Livestock: Pigs (PB7050):  
<http://www.defra.gov.uk/animalh/welfare/farmed/pigs/pigcode.pdf>
- Guidelines for farmers in NVZs (PB5505):  
<http://www.defra.gov.uk/environment/water/quality/nitrate/library.htm>
- Manure Planning in NVZs (PB5504):  
<http://www.defra.gov.uk/environment/water/quality/nitrate/library.htm>
- Manure Management Plan: a step-by-step guide for farmers:  
<http://www.defra.gov.uk/environ/pollute/farmwaste.htm>
- Fertiliser recommendations for agricultural and horticultural crops (RB209) is available from the Stationery Office – see below or can be downloaded in sections via:  
<http://www.defra.gov.uk/environ/pollute/rb209/index.htm>
- Controlling soil erosion: <http://www.defra.gov.uk/environment/land/soil/controlling>
- Ammonia emissions from irrigation of dilute pig slurry. R&D Report WA0715.

The following three booklets are also available free of charge from ADAS Gleadthorpe Research Centre (Tel: 01623 844331).

- Managing Livestock Manures Booklet 1 Making better use of livestock manures on arable land: <http://www.defra.gov.uk/environ/pollute/farmwaste.htm>
- Managing Livestock Manures Booklet 2 Making better use of livestock manures on grassland: <http://www.defra.gov.uk/environ/pollute/farmwaste.htm>
- Managing Livestock Manures Booklet 3 Spreading systems for slurries and solid manures: <http://www.defra.gov.uk/environ/pollute/farmwaste.htm>

### **National Office of Animal Health (NOAH)**

- Website: [www.noah.co.uk](http://www.noah.co.uk).
- Telephone: 020 8367 3131
- Email: [noah@noah.co.uk](mailto:noah@noah.co.uk)
- Address: National Office of Animal Health, 3 Crossfield Chambers, Gladbeck Way, Enfield, EN2 7HF.

The NOAH Compendium of Data Sheets for Veterinary Products can be obtained from the website.

### **British Pig Executive(BPEX)/Meat and Livestock Commission (MLC)**

- Website: [www.bpex.org.uk](http://www.bpex.org.uk)
- Telephone: 01908 844368
- Email: [bpex@mlc.org.uk](mailto:bpex@mlc.org.uk)
- Address: PO Box 44, Winterhill House, Snowdon Drive, Milton Keynes, MK6 1AX

Useful publications:

- Environmental factors in pig production. Description of potential emissions, causes, abatement and legislation: <http://www.stofoldpigs.co.uk/publish/pdfs/environ.pdf>

- Environmental Management for Healthy Pig Production:  
[http://www.bpex.org/technical/publications/pdf/Environmental\\_management.pdf](http://www.bpex.org/technical/publications/pdf/Environmental_management.pdf)

## **Construction Industry Research and Information Association (CIRIA)**

- Website: [www.ciria.org](http://www.ciria.org)
- Telephone: 020 7549 3300
- Email: [enquiries@ciria.org](mailto:enquiries@ciria.org)
- Address: Classic House, 174-180 Old Street, London EC1V 9BP

CIRIA report 126 'Farm waste storage - guidelines for construction' can be purchased from CIRIA or obtained through a library - ISBN: 0-86017-352-6.

## **The Stationery Office**

- Website: [www.tso.co.uk](http://www.tso.co.uk)
- Telephone enquiries/orders: 0870 600 5522
- Email: [book.enquiries@theso.co.uk](mailto:book.enquiries@theso.co.uk)
- Address: TSO Publications Centre, PO Box 276, London SW8 5DT

The following regulations can be downloaded from Office of Public Sector Information website (formerly HMSO) ([www.opsi.gov.uk](http://www.opsi.gov.uk)) or obtained in printed copy from The Stationery Office:

- The Pollution Prevention and Control (England and Wales) Regulations 2000. S.I. 2000 No. 1973: <http://www.opsi.gov.uk/si/si2000/20001973.htm>
- The Control of Pollution (Silage, Slurry and Agricultural Fuel Oil) Regulations 1991. S.I. 1991 No. 324: [http://www.opsi.gov.uk/si/si1991/Uksi\\_19910324\\_en\\_1.htm](http://www.opsi.gov.uk/si/si1991/Uksi_19910324_en_1.htm)
- The Control of Pollution (Silage, Slurry and Agricultural Fuel Oil) (Amendment) Regulations 1997. S.I. 1997 No. 547: <http://www.opsi.gov.uk/si/si1997/19970547.htm>
- The Sludge (Use in Agriculture) Regulations 1989. S.I. 1989 No. 1263: [http://www.opsi.gov.uk/si/si1989/Uksi\\_19891263\\_en\\_1.htm](http://www.opsi.gov.uk/si/si1989/Uksi_19891263_en_1.htm)
- The Groundwater Regulations 1998. S.I. 1998 No. 2746: <http://www.opsi.gov.uk/si/si1998/19982746.htm>
- The Animal By-Products Regulations 2003. S.I. 2003 No. 1482: <http://www.opsi.gov.uk/si/si2003/20031482.htm>
- The Action Programme for Nitrate Vulnerable Zones (England and Wales) Regulations 1998. S.I. 1998 No. 1202: <http://www.opsi.gov.uk/si/si1998/19981202.htm>
- The Nitrate Vulnerable Zones (Additional Designations) (England) (No. 2) Regulations 2002. S.I. 2002 No. 2614: <http://www.opsi.gov.uk/si/si2002/20022614.htm>
- The Protection of Water Against Agricultural Nitrate Pollution (Amendment) (Wales) Regulations 2002. Welsh S.I. 2002 No. 2297 (W.226): <http://www.opsi.gov.uk/legislation/wales/wsi2002/20022297e.htm>
- Welfare of Farmed Animals (England) (Amendment) Regulations 2003. S.I. 2003 No. 299: <http://www.opsi.gov.uk/si/si2003/20030299.htm>
- The Waste Management (England and Wales) Regulations 2006. S.I. 2006 No. 937. 'The Agricultural Waste Regulations': [http://www.opsi.gov.uk/si/si2006/uksi\\_20060937\\_en.pdf](http://www.opsi.gov.uk/si/si2006/uksi_20060937_en.pdf)

- Policy and Practice for the Protection of Groundwater, with accompanying groundwater protection maps. Environment Agency, 1998. ISBN 0113101457
- Code of Practice for the Agricultural Use of Sewage Sludge. Department of the Environment 1989. ISBN 1 85112 005 X
- Fertiliser Recommendations for Agricultural and Horticultural Crops – Reference Book 209, Defra. ISBN 0 11 242813 4.

### **European Integrated Pollution Prevention and Control Bureau**

Reference Document on Best Available Techniques for Intensive Rearing of Poultry and Pigs, July 2003, available from <http://eippcb.jrc.es/pages/FActivities.htm>.

### **English Nature**

- Website: <http://www.english-nature.org.uk/>
- Telephone: 01733 455000
- Email: [enquiries@english-nature.org.uk](mailto:enquiries@english-nature.org.uk)
- Address: English Nature, Northminster House, Peterborough, PE1 1UA

Details of the locations of Sites of Special Scientific Interest (SSSIs) and European designated conservation sites (Special Areas of Conservation, SACs, and Special Protection Areas, SPAs) can be obtained from interactive maps on the English Nature website: <http://www.natureonthemap.org.uk>.

Maps can also be purchased on-line or contact your local English Nature team – see the website or your phone book for contact details.

Maps of conservation sites can also be downloaded from MAGIC - Multi-Agency Geographic Information for the Countryside: [www.magic.gov.uk](http://www.magic.gov.uk).

### **Health and Safety Executive**

- Website: [www.hse.gov.uk](http://www.hse.gov.uk)
- Telephone: 08701 545500
- E-mail: [hseinformationservices@natbrit.com](mailto:hseinformationservices@natbrit.com)
- Address: HSE Infoline, Caerphilly Business Park, Caerphilly, CF83 3GG

Agriculture Homepage: <http://www.hse.gov.uk/agriculture/index.htm>

Guide to Pesticides (The Blue Book) Electronic Copy:  
<http://www.hse.gov.uk/pesticides/bluebook/>

### **Farm Energy Centre**

- Website: [www.farmenergy.com](http://www.farmenergy.com)
- Telephone: 0247 669 6512
- Email: [info@farmenergy.org.uk](mailto:info@farmenergy.org.uk)
- Address: Farm Energy Centre, NAC Stoneleigh Park, Kenilworth, Warwickshire, CV8 2LS

Information on energy auditing on farms can be obtained via:  
<http://www.farmenergy.com/services3.html>

A range of publications can be ordered from the Farm Energy Centre. The following can be downloaded from the website:

- Technical Note TN 44 - Poultry Energy Efficiency:  
<http://www.farmenergy.com/livestock-tn44.html>
- Technical Note TN37 - Energy Efficiency in Pig Production:  
<http://www.farmenergy.com/pig-tn37.html>

### **The Carbon Trust**

- Website: [www.thecarbontrust.co.uk](http://www.thecarbontrust.co.uk)
- Telephone helpline: 0800 085 2005
- Address: The Carbon Trust, 8th Floor, 3 Clement's Inn, London, WC2A 2AZ

The Energy Consumption Guide 'Energy Use in Pig Farming' can be obtained via the website or from the NPA website via: [http://www.npa-uk.net/ds\\_portal/library/Carbon%20Trust%20Pig%20Farming%20ECG0891.pdf](http://www.npa-uk.net/ds_portal/library/Carbon%20Trust%20Pig%20Farming%20ECG0891.pdf)

### **British Standards**

- Website: [www.bsi-global.com](http://www.bsi-global.com)
- Telephone: 020 8996 9000
- Email: [cservices@bsi-global.com](mailto:cservices@bsi-global.com)
- Address: 389 Chiswick High Road, London, W4 4AL

BS 5502-50:1993. Buildings and structures for agriculture. Code of practice for design, construction and use of storage tanks and reception pits for livestock slurry.

### **ACORUS**

- Website: [www.acorus.org](http://www.acorus.org)
- Telephone: North 0113 260 8645,  
Midlands & Wales 01902 693 213  
South & East 01284 753 271  
South West 01626 892 638
- Online enquiry service: <http://www.acorus.org/enquiryform.htm>

Construction Guidance Notes can be obtained via <http://www.acorus.org/cgn.htm> including:

- CGN 100 Organising contracts for farm waste structures (manure and slurry);
- CGN 001 Above-ground circular concrete and rectangular weeping-wall slurry stores;
- CGN 002 Earth-banked slurry stores;
- CGN 003 In-situ concrete slurry stores;
- CGN 004 Above-ground circular steel slurry stores;
- CGN 008 Separation of Clean and Dirty Water, Dirty Water Storage, Yard Area Construction;
- CGN 009 Bunds for Agricultural Fuel Oil Tanks;
- CGN 010 Sluice valves on steel and concrete circular above-ground slurry stores;
- CGN 011 The use of covers on circular steel and concrete slurry stores.

## Appendix 1 Protocol for sampling slurry and solid manure for analysis<sup>1</sup>

### A1.1 Why correct sampling matters

The nutrient content of slurry can vary considerably within a store due to settlement and crusting. Similarly, the composition of solid manure in a heap can vary depending on the amount of bedding and losses of nutrients during storage.

If stored materials are to be analysed either in a laboratory or by a rapid on-farm method, it is important that the sample taken represents an 'average' of what is found in the store or heap.

### A1.2 General principles of sampling

It is important, where this is practical and safe, to take a number of samples. Take these from a range of positions within the store or heap, bulk them together, mix them and then take a representative sub-sample.

The final sample can be sent to the laboratory for analysis or tested with a slurry N meter or slurry hydrometer on-farm depending on whether information is needed to draw up a full Manure Management Plan, or as a check on earlier data once spreading is in progress.

### A1.3 Slurries

Take at least five sub-samples of 2 litres, pour into a larger container, stir thoroughly and pour a 2 litre sample immediately into a smaller clean container to provide the sample for analysis.

#### Above-ground stores

Ideally, slurry should be fully agitated and sub-samples taken from the reception pit. If this is not possible, and provided there is safe access from an operator's platform, the five sub-samples can be taken at a range of positions, using a weighted 2 litre container attached to a rope.

#### Below-ground pits

It may be possible to obtain sub-samples at various positions using a weighted container as above, but never enter the pit, as lethal gases may be present. Do not attempt to take samples during or soon after slurry agitation as large amounts of lethal gases may be released from the stirred slurry.

#### Earth-banked lagoons

If the slurry has been well agitated, sub-samples can be obtained from the tanker or irrigator as outlined below. Do not attempt to sample direct from the lagoon unless there is a secure operator's platform that provides safe access.

#### Sampling while spreading

If the tanker is fitted with a suitable valve, it may be possible to take five sub-samples from the stationary slurry tanker at intervals while field spreading is in progress. Or, trays placed in the field can be used to collect samples while the material is being spread.

---

<sup>1</sup> Based on 'Managing Livestock Manures, Booklet 3: Spreading Systems for Slurries and Solid Manures'. MAFF/ADAS/IGER/SRI November 2000.

## **A1.4 Solid manures**

Take at least ten sub-samples of about 1kg each, taken as described below, and place on a clean, dry tray or sheet. Break up any lumps and thoroughly mix the sample. Then take a representative sample of around 2kg for analysis (you should check the weight required with the laboratory).

### **Manure Heaps**

Provided the manure is dry and safe to walk on, identify at least ten locations which appear to be representative of the heap. Having cleared away any weathered material with a spade or fork, dig a hole approx. 0.5m deep and take a 1kg sample from each point. Alternatively, take sub-samples from the face of the heap at various stages during spreading.

### **Weeping-wall stores**

Do not attempt to take samples before the store is emptied as it is not safe to walk on the surface of the stored material. Sub-samples may be taken from the face of the heap once emptying has commenced.

### **Sampling during spreading**

Trays placed in the field can be used to collect samples while the material is being spread. Take care to avoid the possibility of injury from stones and other objects which may be flung out by the spreading mechanism.

## **A1.5 Storage and analysis**

If you analyse slurry using an on-farm rapid method, do this immediately after sampling, making sure that the sample taken is well mixed.

If you send samples to a laboratory for analysis slurry should be dispatched in clean screw-topped 2 litre plastic containers. Leave at least 5cm of airspace to allow the sample to be shaken in the laboratory. For manures, use 500-gauge polythene bags and expel excess air from the bag before sealing.

Clearly label the samples on the outside of the container or bag and dispatch them immediately or within a maximum of seven days if kept in a refrigerator.

## Appendix 2 Minimising emissions from new pig housing - examples of housing designs from the BREF

The following examples of housing designs are taken from the Reference Document on Best Available Techniques (BAT) for Intensive Rearing of Poultry and Pigs, commonly referred to as the BREF, published in July 2003 by the European IPPC Bureau. These sections are reproduced here so that you do not need to obtain and read the BREF which is 341 pages long. If required, the full document can be downloaded at <http://eippcb.jrc.es/pages/FActivities.htm>. As this text is taken from a European document all costs are stated in Euros.

This appendix will be updated as further information becomes available on these housing designs and as new techniques and designs are evaluated and considered to be BAT.

The following examples are divided into sections for sows, farrowing sows including piglets, weaners and growers/finishers. Each section is then sub-divided into the housing designs referred to in the appropriate measures with the relevant BREF section reference included in the sub-section heading.

### A2.1 Sows

#### A2.1.1 Partly-slatted floor with a reduced area manure pit (BREF 4.6.1.4)

**Description:** Ammonia emissions can be reduced by reducing the manure surface area, in particular by applying a small manure pit with a maximum width of 0.60m. The manure pit is equipped with triangular iron slats or concrete slats. The sows are individually housed.

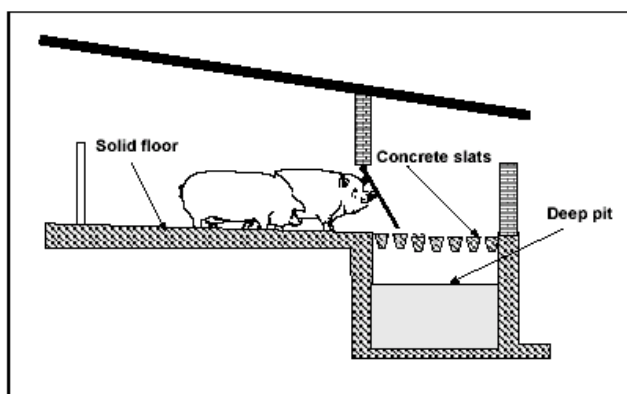

#### Solid concrete floor and fully-slatted external alley with storage pit underneath

In Italy a loose-housing design is applied with a fully-slatted external alley with the slurry pit underneath; the slurry not being removed very frequently. Indoors, the animals are kept on a solid concrete floor, a hatched opening giving access to the external alley. This design can not be compared with the systems for loose-housed sows with the partly-slatted floors inside the housing. The applied reduction techniques show similar environmental performances and operating conditions, but may differ slightly in costs.

**Achieved environmental benefits:** The combination of the reduction of the manure pit and slurry surface and the fast discharge of manure by using triangular slats reduce NH<sub>3</sub>-emissions by 20 to 40 %. In a system, individual housing and group housing show different emissions due to the differences in manure emitting surface per sow. With loose housing of sows, levels are reported to be 2.96 kg NH<sub>3</sub> per sow place per year (Italy). For the individual housing of sows levels of 1.23 (Denmark) and 2.40 (Netherlands) NH<sub>3</sub> per sow place per year respectively have been reported.

**Cross-media effects:** These houses can be naturally or mechanically ventilated. In Denmark mechanical ventilation is applied and dimensioned for an output of a maximum of 100 m<sup>3</sup> per hour per sow place. In areas with low outdoor temperatures these units can also be equipped with auxiliary heating. Energy input is unchanged. In the case of the external slurry pit, a reduced emission will not benefit the internal environment, which can be considered as one of the advantages of the reduced pit inside. In Italy energy savings are possible because artificial ventilation is not required.

**Operational data:** The slurry is usually removed via a central sewer system by opening a valve and using inclination of the manure pipe. Some systems are equipped with scrapers.

**Applicability:** In existing houses, the applicability depends on the design of the existing manure pit, but it is mostly difficult, if not impossible, to apply. For existing housings with an internal concrete solid floor an extension with an external alley with a storage pit might be possible. The application of a maximum width of 0.60 m may require more pit depth or more frequent removal and then outside manure storage. If a minimum pit size is imposed then by relation, a reduction will not be applicable, (e.g. Ireland: > 0.90 m). In some European countries (e.g. DK) the individual housing of sows will decline because of changing legislation stipulating loose-housing systems.

**Costs:** The remaining ammonia emission compared with a fully-slatted floor depends on the reference. With a 40 % reduction (4.2 to 2.4 kg NH<sub>3</sub>), the additional investment is about EUR 17.75 per sow place or EUR 9.85 per kg NH<sub>3</sub> abated. Additional annual operating costs are EUR 5.80 per sow place or EUR 3.25 per kg NH<sub>3</sub>. With a 20 % reduction, an additional investment of EUR 1.76 per sow place was reported. The system with the external manure pit and slatted floor reportedly had an additional investment of EUR 8.92 per sow place per year.

**Reference farms:** This is a very common housing system for mating and gestating sows in many European Member States. In Italy 40 % of the growers/finishers are kept in these kind of installations.

#### **A2.1.2 A fully-slatted floor with vacuum system for frequent slurry removal (BREF 4.6.1.1)**

**Description:** On the bottom of the pit under a fully-slatted or part-slatted floor, outlets are placed every 10 m<sup>2</sup> and that are connected to a sewerage system. Slurry is discharged by opening a valve in the main slurry pipe. A slight vacuum develops and allows the slurry removal. The pit can be emptied once or twice a week, depending on the capacity of the pit itself.

**Achieved environmental benefits:** Reduction of NH<sub>3</sub>-emission by about 25% due to frequent removal of slurry. Italian data reported about 2.77 kg NH<sub>3</sub> per sow place per year.

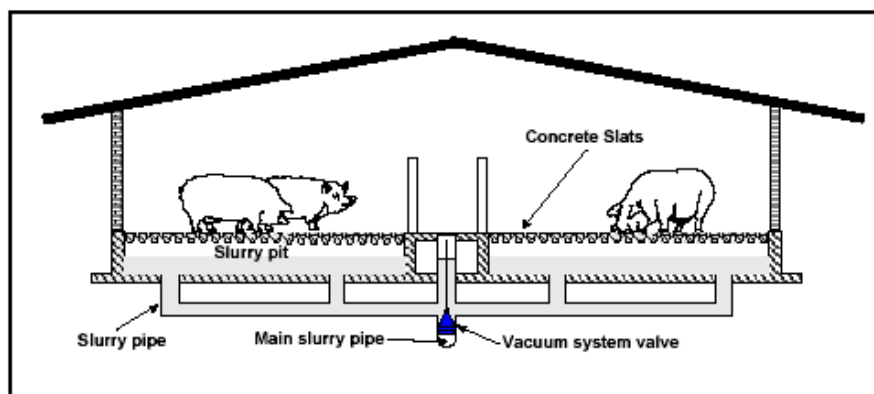

### Fully-slatted floor with vacuum system

**Cross-media effects:** As the system is manually operated, no additional energy is required. Less water is needed to clean the floor compared to partly-slatted or solid concrete floors. It is suggested that any aerosols which develop during the discharge of the slurry are removed by the vacuum created when opening the valves.

**Operational data:** This technique is easy to operate compared to the reference technique.

**Applicability:** In existing houses, this technique may be applicable with:

- solid concrete floors and with sufficient height to build on top of the existing floor
- renovation of a FSF with a storage pit underneath.

**Costs:** Italy reported a negative extra cost (i.e. a benefit) of EUR 8.60 per sow place per year, when applied in new housing, compared to the costs of the reference system.

**Reference farms:** An increasing number of farms in Italy are adopting this technique in new housing for gestating sows, e.g. Sartori farm, Parma.

### A2.1.3 A partly-slatted floor with vacuum system for frequent slurry removal (BREF 4.6.1.6)

**Description:** cross-media effects: See A2.1.2.

**Achieved environmental benefits:** With a partially slatted floor and a vacuum system the NH<sub>3</sub>-emission is reduced to 2.77 kg NH<sub>3</sub> per sow place per year on concrete slats, and to 2.40 kg NH<sub>3</sub> per sow place per year on metal slats for loose housed sows. This compares with the reference as relative reductions of 25 % and 35 % respectively.

**Operational data:** This technique is easy to operate compared to the reference technique.

**Applicability:** In existing housing application, its applicability is limited to housing with partially slatted floors and a storage pit with sufficient depth.

**Costs:** There are no data available on capital costs, but the annual operational costs are thought to be the same as for growers/finishers and this is an estimated negative extra cost (i.e. a benefit) of EUR 4 when concrete slats are applied and EUR 1.50 (also a benefit) when metal slats are applied in a new housing.

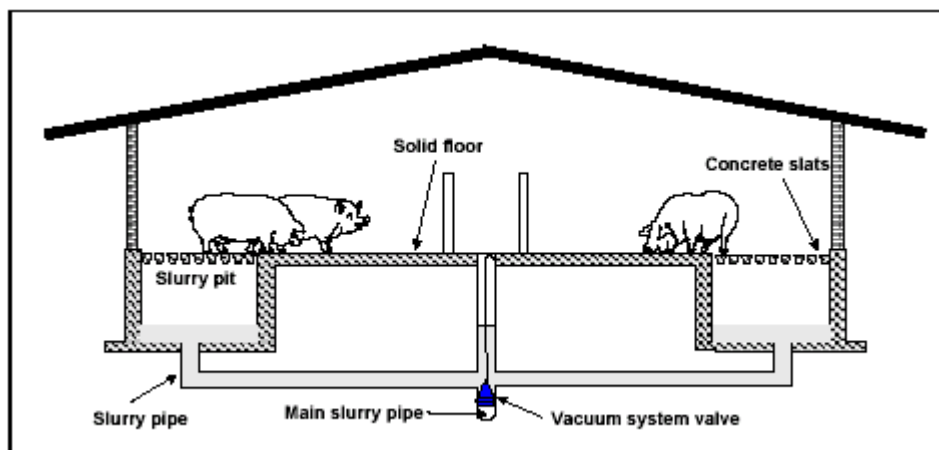

Partly-slatted floor with vacuum system

## A2.2 Farrowing sows including piglets

### A2.2.1 Farrowing pen with part or fully-slatted iron or plastic floor with a combination of water and manure channel (BREF 4.6.2.2)

**Description:** The sow has a fixed place and as a result it is clear where the dunging area will be. The manure pit is split up into a wide water channel at the front and a small manure channel at the back. This greatly reduces the manure surface, which in turn reduces the ammonia emission. The front channel is partly filled with water. The slats are made of iron or plastic.

**Achieved environmental benefits:** It limits the manure surface and has frequent removal of the slurry by a sewerage system. A reduction of 52 % (4.0 kg NH<sub>3</sub> per sow place per year (NL, B)) can be achieved.

**Cross-media effects:** The frequent removal of the slurry may require extra energy. Water is needed to fill the front pit.

**Applicability:** This system is easy to implement in the reconstructions of existing buildings with the reference technique, as the design of the pen is not critical for the applicability of the system. Very simply, all that would be needed would be separation of the two pits.

**Operational data:** Supposedly the two pits are emptied into the same slurry sewerage system towards the slurry store. Water is changed after each round (approximately 4 weeks). The front section is drained completely, cleaned, disinfected and then filled up again with fresh water.

**Costs:** The extra investment costs are EUR 60 per pig place. This means for a 52 % reduction about EUR 13.85 per kg NH<sub>3</sub> abated. The extra annual operational costs are EUR 1.00 per pig place or EUR 0.25 per kg NH<sub>3</sub>.

**Reference farms:** In the Netherlands 5000 sow places are equipped with this system.

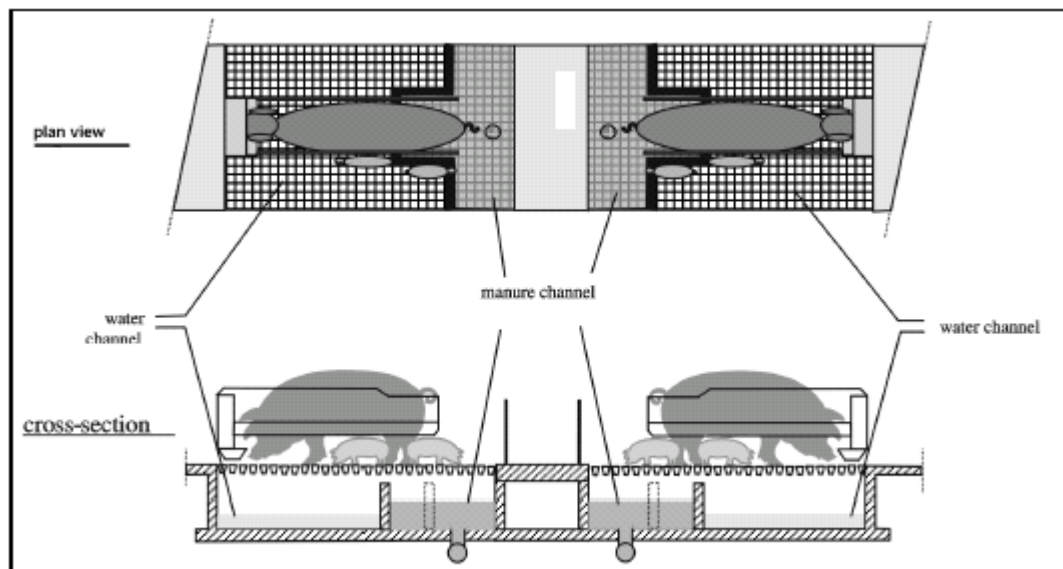

### Combination of a water and manure channel

#### A2.2.2 Farrowing pen with part or fully-slatted iron or plastic floor with a flushing system with manure gutters (BREF 4.6.2.3)

**Description:** Small gutters limit the manure surface. This reduces the ammonia emission. Application is possible in pens with a partly or fully-slatted floor. The manure is removed frequently by a flushing system. The slats are made of triangular iron slats. The gutter sides should have a slope of 60 degrees. The gutters should be flushed twice a day.

**Environmental benefit:** Limiting the manure surface in the manure channel, in combination with fast discharging of the manure from the slatted area by using plastic or iron triangular bars, and removing the manure twice a day by flushing reduces NH<sub>3</sub> emissions by 60 % (3.3 kg NH<sub>3</sub> per sow place per year (NL, B))

**Cross-media effects:** This system has an extra energy consumption of 8.5 kWh per sow place per year, related to the flushing of the gutters. Odour peaks due to flushing may cause a nuisance when receptors are living near the farm. On a case by case basis it has to be decided whether an overall load (thus applying a no-flushing system) or peak values are more important.

**Applicability:** In existing houses the applicability depends on the design of the existing manure pit, but it does not seem difficult with the reference system.

**Costs:** The extra investment costs are EUR 535 per sow place. This means with a 60 % reduction, i.e. 8.3 to 3.3 kg NH<sub>3</sub>, costs are EUR 107 per kg NH<sub>3</sub> abated. The extra operational costs per year are EUR 86.00 per pig place. This means EUR 17.20 per kg NH<sub>3</sub>. To achieve a slightly better reduction extra costs are considerably higher than those reported for the system with a separated water and manure channel. This difference could not be explained from the submitted information.

**Reference farms:** In the Netherlands, about 500 farrowing sow places are equipped with this system.

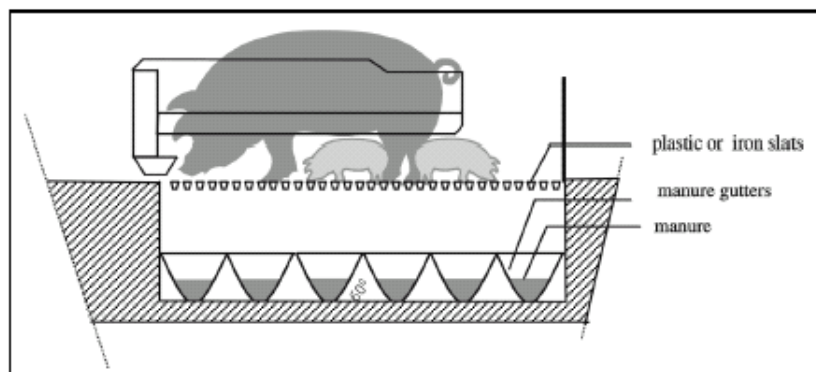

### Flushing system with manure gutters

#### A2.2.3 Farrowing pen with part or fully-slatted iron or plastic floor with a manure pan underneath (BREF 4.6.2.4)

**Description:** A prefabricated pan is placed under the slatted floor and can be adapted to the dimensions of the pen. The pan is deepest at one end of the pen and the pan has a slope of at least 3° towards a central slurry channel. The pan is connected with a sewerage system. Every three days the manure should be removed by the sewerage system. The application does not depend on the pen design, or on whether it is with a fully or a partly-slatted floor. The slats are made of iron or plastic.

**Environmental benefit:** Limiting the manure surface and frequent removal of the slurry by a sewerage system achieves a 65 % reduction of NH<sub>3</sub>-emissions (2.9 kg NH<sub>3</sub> per sow place per year). An increased reduction of 50 % compared with the sloped board construction is achieved, although both designs seem to be very similar. A lower emitting surface and a more frequent removal of the slurry is considered to be the most important factors determining the difference.

**Applicability:** This system is easy to implement in reconstructions of existing buildings. The design of the pen is not critical for the applicability of the system.

**Costs:** The extra investment costs are EUR 280 per pig place. This means with a 65 % reduction, i.e. 8.3 to 2.9 kg NH<sub>3</sub>, costs are EUR 53.85 per kg NH<sub>3</sub> abated. The extra operational costs per year are EUR 45.85 per pig place. This means EUR 8.80 per kg NH<sub>3</sub>.

**Reference farms:** In the Netherlands, about 10000 sow places are equipped with this system. This system has only recently been developed (1998). Currently this system is being implemented in many reconstructions as well as in new buildings.

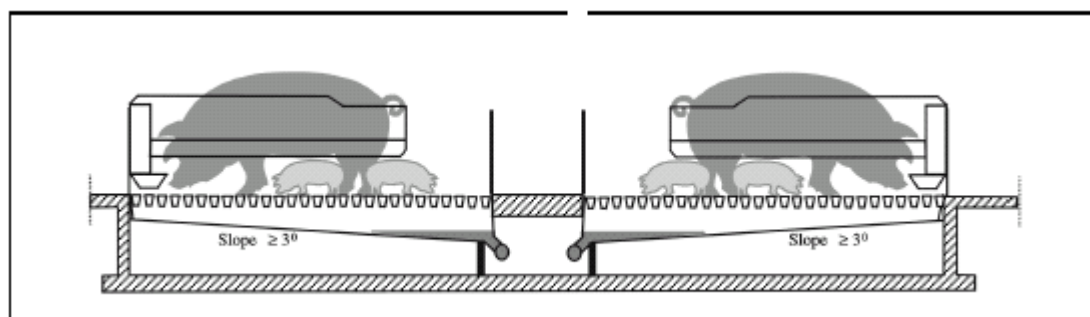

### Fully-slatted floor with manure pan

## A2.3 Weaners

### A2.3.1 Slurry systems with a pen or flatdeck with a fully-slatted (BREF 4.6.1.1) or partly-slatted (BREF 4.6.1.6) floor with a vacuum system for frequent slurry removal

See A2.1.2 and A2.1.3 for details.

### A2.3.2 Slurry systems with a pen or flatdeck with a fully-slatted floor beneath which there is a concrete sloped floor to separate faeces or urine (BREF 4.6.3.1)

**Description:** A board (concrete or other material) with a very smooth surface is placed under the slatted floor. The size can be adapted to the dimensions of the pen. The board has a slope of at least 12° towards a central slurry pit, which is connected with a sewerage system. The slurry is removed weekly to a store by gravity or by pumping. The slats are made of iron or plastic. At the end of the weaning period, dry faeces are easily removed by water jets.

**Achieved environmental benefits:** Immediate removal of manure to central channel and immediate draining of urine achieves reduction of 30 % (0.42 kg NH<sub>3</sub> per pig place per year (l)).

**Cross-media effects:** There is no additional energy required.

**Applicability:** With a manure pit of sufficient depth, this technique can be easily applied in existing housing.

**Costs:** Investment costs are estimated to be less than the reference, if the benefits are included in costs calculation.

**Reference farms:** A few applications in Italy.

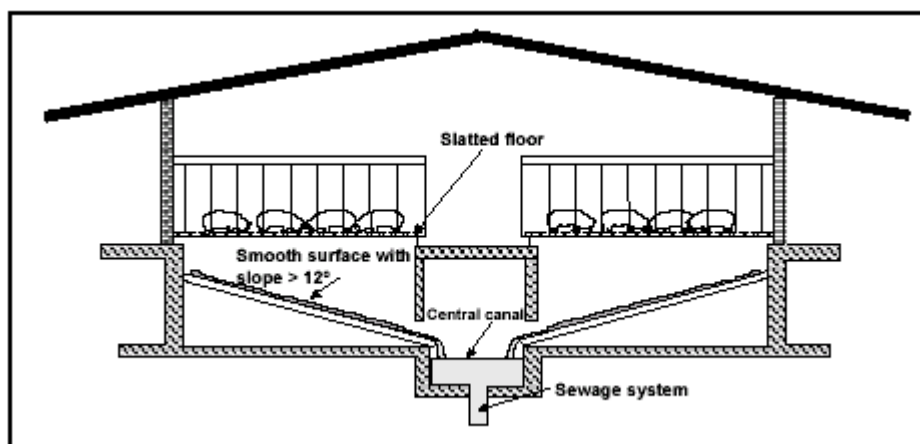

**Flatdecks or pens with concrete sloped floor underneath to separate faeces and urine**

### A2.3.3 Slurry systems with a pen with a partly-slatted floor (two climate system) (BREF 4.6.3.4)

**Description:** Manure is handled as a slurry. It is often drained through a pipe discharge system where the individual sections of the manure channels are drained via plugs in the discharge pipes. The channels can also be emptied via gates. The channels are drained after the removal of each group of pigs, often in connection with disinfecting the pens, i.e. at intervals of 6 - 8 weeks.

**Achieved environmental benefits:** A reduction in ammonia emissions by 34 % (0.53 kg NH<sub>3</sub> per pig place per year) is achieved when applying this technique. This technique has been applied in Denmark and its performance is therefore compared with the emission level of the reference obtained in Denmark (0.8 kg NH<sub>3</sub> per pig place per year).

**Cross-media effects:** The naturally ventilated design uses less energy compared to the reference.

**Operational data:** This housing type is normally equipped with mechanical ventilation, either in the form of negative-pressure or balanced-pressure ventilation. The ventilation is dimensioned for a maximum output of 40 m<sup>3</sup> per hour per place. Auxiliary heating is available in the form of either electric fan heaters or a central heating plant with heating pipes. Naturally ventilated designs are also applied.

**Applicability:** This system is applicable in new and existing installations.

**Costs:** The extra investment costs and operational costs are estimated to be equal to the reference system.

**Reference farms:** It is estimated that in Denmark 30 – 40 percent of the weaners, corresponding to about 1600000 places, are housed on partly-slatted floors weighing from 7.5 to 30 kg. This figure is expected to increase.

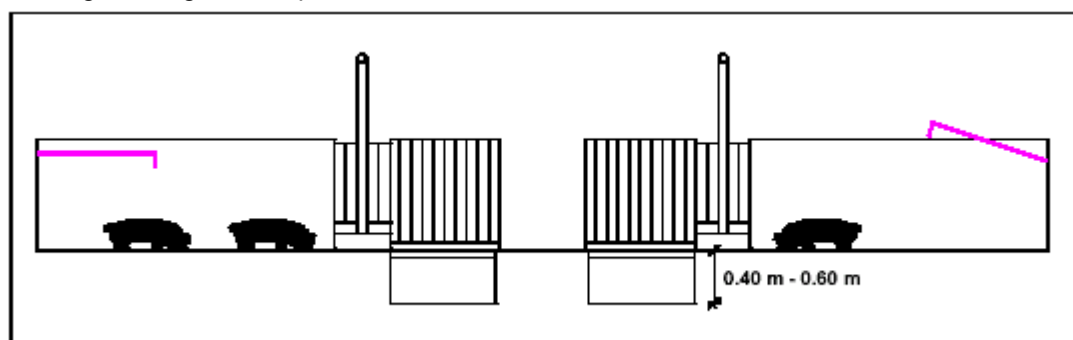

**Cross-section of rearing unit with partly-slatted floor, two climate**

#### **A2.3.4 Slurry systems with a pen with a partly-slatted iron or plastic floor and a sloped or convex solid floor (BREF 4.6.3.5)**

**Description:** Using a partly solid concrete floor reduces the manure surface which reduces the ammonia emission. Application is possible in pens with a convex floor. The convex floor separates the two channels. Application is also possible in pens with a partly-slatted floor consisting of a solid concrete floor on a slope in front of the pen. The slats can be iron or plastic (not concrete slats).

**Achieved environmental benefits:** Limiting the manure surface in the manure channel achieves a reduction of 43 % (0.34 kg NH<sub>3</sub> per pig place per year). The reduction can in fact only be achieved by changing the design of the pen. This design is similar to the previous design, although a higher reduction is achieved, which is attributed to the convex or sloped floor.

**Operational data:** It is assumed that this is similar to the reference system.

**Applicability:** The system with partly-slatted floor or a convex floor can be applied in new houses. In existing houses the applicability depends on the design of the existing manure pit.

**Costs:** Extra investment is not needed if this alternative could be applied instead of a fully-slatted floor. Annual costs are also similar.

**Reference farms:** At least 10000 piglet places have been equipped with this system in the Netherlands.

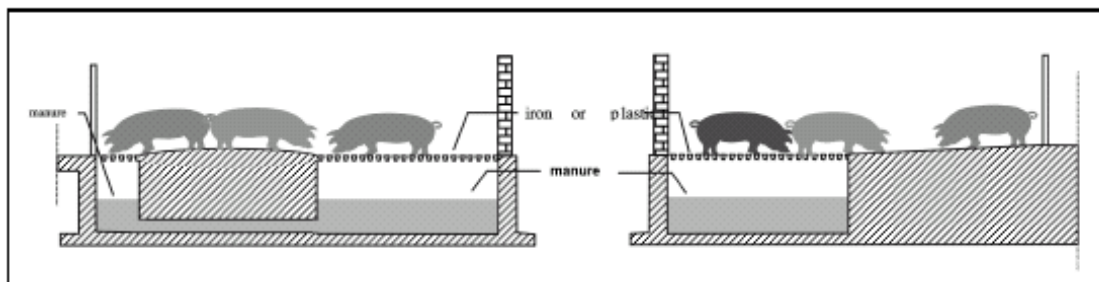

**Partly-slatted floor with iron or plastic slats and convex or sloped concrete floor**

**A2.3.5 Slurry systems with a pen with a partly-slatted metal or plastic floor and a shallow manure pit and channel for spoiled drinking water (BREF 4.6.3.6)**

**Description:** Using a partly solid concrete floor reduces the manure surface which reduces the ammonia emission. Application is possible in pens with a convex floor. The convex floor separates the two channels. The front channel is partly filled with water, as the pigs don't normally use the front area as a dunging area. Only spoiled feed concentrates come into the front channel. The main function of the water is to prevent flies breeding.

**Achieved environmental benefits:** Limiting the manure surface in the manure channel, together with quickly discharging the manure on the slatted area by using iron triangular bars and removing the manure frequently by a sewerage system reduces emissions by 57 % (0.26 kg NH<sub>3</sub> per pig place per year (NL, B)).

**Cross-media effects:** No extra energy required.

**Operational data:** It is assumed to be similar to the reference system.

**Applicability:** In existing houses the applicability depends on the design of the existing manure pit.

**Costs:** The extra investment is EUR 2.85 per pig place. The extra annual operational costs are EUR 0.35 per pig place.

**Reference farms:** In the Netherlands, about 250000 weaner places have been equipped with this system.

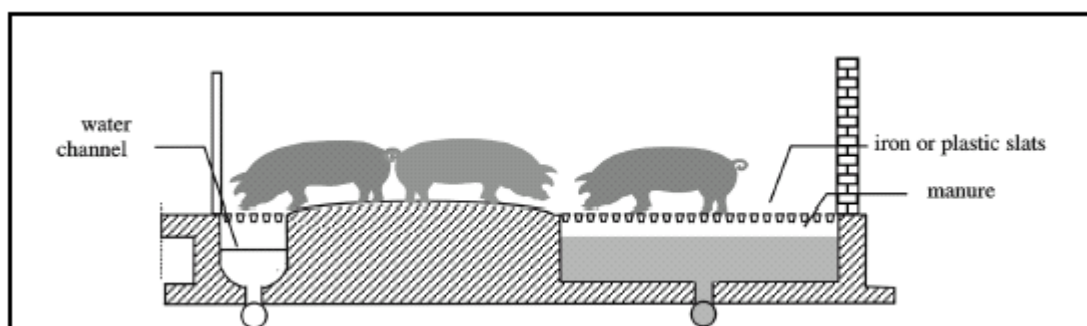

**Shallow manure pit with a channel for spoiled drinking water in front in combination with a convex floor with iron or plastic slats**

### A2.3.6 Slurry systems with a pen with a partly-slatted floor with triangular iron slats and a manure channel with sloped side walls (BREF 4.6.3.9)

**Description:** Side wall(s) on a slope reduce the manure surface which reduces the ammonia emission. Application is possible in pens with a convex floor. The convex floor separates the two channels. The front channel is partly filled with water, as the pigs do not normally use the front area as a dunging area. Only spoiled feed concentrates come into the front channel. The main function of the water is to prevent flies breeding. Application is also possible in pens with a partly-slatted floor consisting of a solid concrete floor on a slope in front of the pen. The manure will be removed frequently by a sewerage system. The slats are made of triangular iron bars. The manure surface in the manure channel should not be larger than 0.07 m<sup>2</sup> per pig place. The surface of the sloping wall(s) should be made of a smooth material to prevent the manure adhering to the surface. A sloping wall at the back is not required, but when a sloping wall is present, then this wall should have a slope between 60 and 90 degrees. The wall next to the solid concrete floor should have a slope of between 45 and 90 degrees.

**Achieved environmental benefits:** Limiting the manure surface in the manure channel, together with a fast discharge of the manure from the slatted area by using iron triangular bars and a frequent removal of the manure by means of a sewerage system achieves a 72 % reduction (0.17 kg NH<sub>3</sub> per pig place per year).

**Cross-media effects:** This system does not need extra energy compared with the reference.

**Operational data:** This is similar to the reference system.

**Applicability:** The system with side wall(s) on a slope can be applied in existing houses, with only a few alterations.

**Costs:** Extra investment costs are EUR 4.55 per pig place. With a 72 % reduction, this means about EUR 10.58 per kg NH<sub>3</sub> abated. Extra annual operational costs are EUR 0.75 per pig place or EUR 1.74 per kg NH<sub>3</sub>.

**Reference farms:** This system is a recent development (1998). Currently this system is being implemented in most new buildings and alterations in the Netherlands.

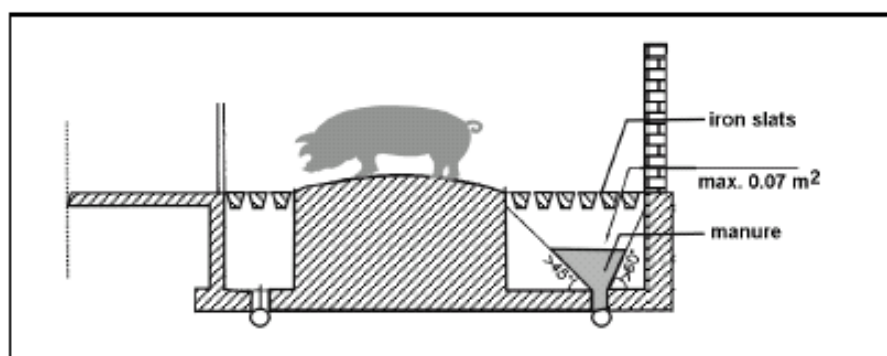

**Convex floor with triangular iron slats in combination with sewerage system and side walls on a slope in the manure channel**

## A2.4 Growers/Finishers

### A2.4.1 Slurry systems with a fully-slatted floor with vacuum system for frequent removal (BREF 4.6.1.1)

See A2.1.2 for details.

### A2.4.2 Slurry systems with a partly-slatted floor with a reduced manure pit, including slanted walls and a vacuum system (BREF 4.6.4.3)

**Description:** See A2.4.3 below where the system applying slanted walls is described and A2.1.2 above where the vacuum system is described. Combining the positive effects of these two techniques results in the PSF with a reduced manure pit, including slanted walls and a vacuum system.

**Achieved environmental benefits:** Due to limiting the manure surface in the manure channel and removing manure frequently by a vacuum system, it is estimated that the emission could be reduced by at least 60 % with concrete slats and by 66 % in the case of triangular iron slats.

**Cross-media effects:** As the system is manually operated, no additional energy is required. It is suggested that the vacuum created when opening the valves removes aerosols developing during discharge of the slurry.

**Operational data:** Similar to the reference system.

**Applicability:** The system with slanted side wall(s) can be applied in new houses. In existing houses the applicability depends on the dimensions of the existing manure pit. To implement this system only a few alterations are needed and hardly any change in management technique or regime are needed. The manure surface should be a maximum of 0.18 m<sup>2</sup> per pig place.

**Costs:** The extra investment costs are EUR 3.00 per pig place. The extra operational costs per year are EUR 0.50 per pig place. The additional vacuum system might require some extra costs. For the iron bars, cost data are slightly different. The extra annual investment costs are EUR 23 per pig place.

**Reference farms:** This combination of techniques has not been applied yet.

### A2.4.3 Slurry systems with a partly-slatted floor with a central convex solid floor at the front of the pen, a manure gutter with slanted sidewalls and sloped manure pit (BREF 4.6.4.2)

**Description:** Side wall(s) on a slope reduce the manure surface. This reduces ammonia emissions. Application is possible in pens with a convex floor. The convex floor separates the two channels. The front channel is partly filled with water, as the pigs do not normally use the front area as a dunging area. Only spoiled feed concentrates come into the front channel. The main function of the water is mainly to prevent flies breeding. Application is also possible in pens with a partly-slatted concrete floor consisting of a solid concrete floor on a slope in front of the pen. The manure will be removed frequently by a sewerage system. The manure channel has a width of at least 1.10 metre. The manure surface in the manure channel should not be larger than 0.18 m<sup>2</sup> per pig place. The surface of the sloping wall(s) should be made of a smooth material to the manure adhering to the surface. A sloping wall at the back is not required, but when a sloping wall is present, then this wall should have a slope of between 60 and 90 degrees. The wall next to the solid concrete floor should have a slope of between 45 and 90 degrees. The slats are made of concrete.

**Achieved environmental benefits:** Limiting the manure surface in the manure channel and removing manure frequently by a sewerage system reduces the emission by 60 % (1.2 kg NH<sub>3</sub> per pig place per year) with concrete slats and by 66 % (1.0 kg NH<sub>3</sub> per pig place per year) in the case of triangular iron bar slats.

**Cross-media effects:** This system does not require any extra energy.

**Operational data:** Similar to the reference system.

**Applicability:** The system with slanted side wall(s) can be applied in new houses. In existing houses the applicability depends on the dimensions of the existing manure pit. To implement this system only a few alterations are needed and hardly any change in management technique or regime are needed. The manure surface should be a maximum of 0.18 m<sup>2</sup> per pig place.

**Costs:** The extra investment costs are EUR 3.00 per pig place. This means with a 60 % reduction (i.e. 3.0 to 1.2 kg NH<sub>3</sub>), costs are about EUR 1.65 per kg NH<sub>3</sub> abated. The extra operational costs per year are EUR 0.50 per pig place. This means EUR 0.28 per kg NH<sub>3</sub> abated. For the iron bars cost data are slightly different. The extra investment costs are EUR 23 per pig place. This means with 65 % reduction about EUR 12 per kg NH<sub>3</sub> abated. The extra annual operational costs are EUR 15 per pig place or EUR 2.70 per kg NH<sub>3</sub> abated.

**Reference farms:** The system with iron triangular bars was developed in the mid-nineties and has been implemented in many new buildings and alterations in the Netherlands.

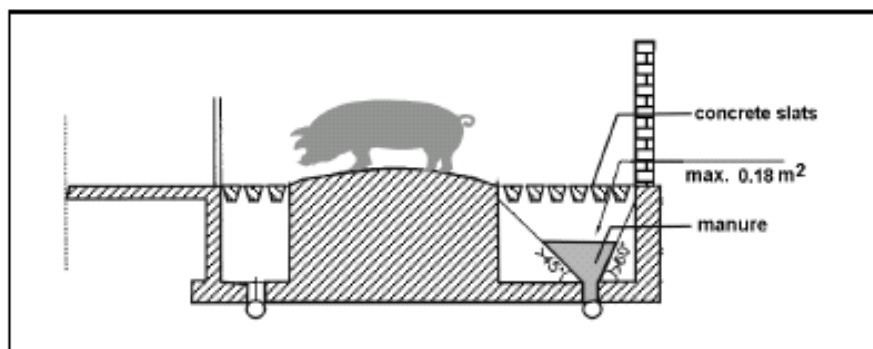

**Convex floor with concrete slats and side walls on a slope in the manure pit**

## Appendix 3 Minimising emissions from new poultry housing - examples of housing designs from the BREF

The following examples of housing designs are taken from the Reference Document on Best Available Techniques (BAT) for Intensive Rearing of Poultry and Pigs, commonly referred to as the BREF, published in July 2003 by the European IPPC Bureau. These sections are reproduced here so that you do not need to obtain and read the BREF which is 341 pages long. If required, the full document can be downloaded at <http://eippcb.jrc.es/pages/FActivities.htm>. As this text is taken from a European document all costs are stated in Euros.

This appendix will be updated as further information becomes available on these housing designs and as new techniques and designs are evaluated and considered to be BAT.

The following examples are divided into sections for laying hens and replacement pullets, broilers and floor reared replacement pullets, turkeys, and ducks. Each section is then subdivided into the housing designs referred to in the appropriate measures with the relevant BREF section reference included in the sub-section heading.

### A3.1 Laying hens and replacement pullets

#### A3.1.1 Caged systems with deep pit with ventilated manure store (BREF 4.5.1.1: deep-pit and canal house)

**Description:** The cages are positioned above the manure storage pit. The height of a deep-pit system measures between 180 and 250 cm. The canal house has a pit, which measures approximately 100 cm. The wet droppings fall in the pit and remain there for periods of up to a year or more. In a deep-pit house as well as in a canal house, fans that are placed below the cages in the lower part of the building draw in ventilation air. The air is drawn into the building through the roof (open ridge system) and passes the cage area, where it is warmed up. The warm airstreams then pass over the manure stored in the pit and leave the house. The manure that is stored in the pit is dried by this flow of warm air. During storage, heating by fermentation occurs. This fermentation results in a high ammonia emission level. To get a good drying result the manure on the plates underneath the cages should be pre-dried for about 3 days. After 3 days the manure has a dry material content of about 35 – 40 %. In the past in the UK, a slat manure drying technique was applied to deep-pit houses with fully stepped and flatdeck systems. It left manure drying in steep sided cones for 6 months, after which the manure was dropped into the deep pit and the slats reset for the rest of the year. This technique may still be applied, but has largely fallen out of use with the demise of most fully stepped and flatdeck cages in deep-pit systems.

**Achieved environmental benefits:** An extractor fan pulls air through the housing past the cages and manure heap. Although the manure is dried with air, some anaerobic fermentation can occur that can cause high ammonia emissions. Reported data on the emission at the outlet of the fans vary between 0.154 (estimated in Italy) and 0.386 (measured in the Netherlands) kg NH<sub>3</sub> per laying hen-place per year. The difference is significant but is probably due to the different climatic conditions. This system shows a better performance in Mediterranean climates than in climates with much lower temperatures. A canal house is assumed to have the same emission levels as a deep pit house. Particularly in winter, when the ventilation rate is lower, ammonia concentrations in the bird area may be reduced, but emissions from the manure storage are not. Providing additional aeration of the manure using perforated polyethylene tubes could achieve lower emissions, but no results have been reported.

**Cross-media effects:** The application of these systems requires energy for the fans, but it must be noted that the fans will serve both the manure storage and the layer housing areas.

**Operational data:** This housing system results in manure with a dry matter of 50 – 60 %. Because the manure is dried so quickly, there is little odour from the cages. The emission appears at the outlets of the open storage. Usually, manure is stored for a full cycle (13 – 15 months). No separate storage facility is needed. In practice, problems are encountered with canal and deep-pit houses because of the level of ammonia concentrations, which can be so high that it is difficult to work in these areas. Flies and dirty eggs may also cause problems, but good maintenance should be able to control this. In the Netherlands this system is being phased out because of the problems with the ammonia emissions, flies and odour.

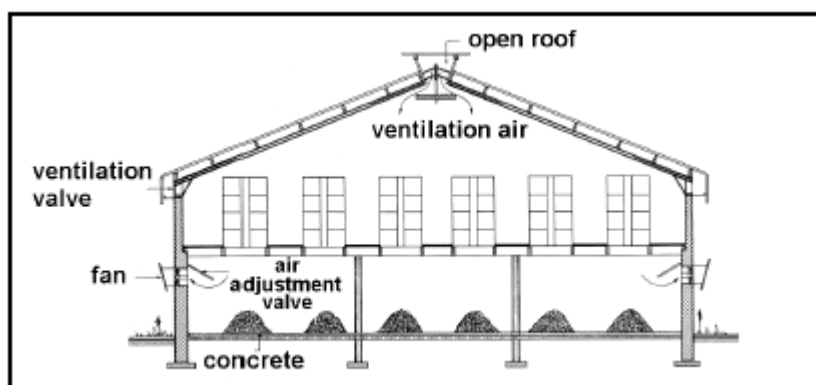

**Deep-pit system for laying hens**

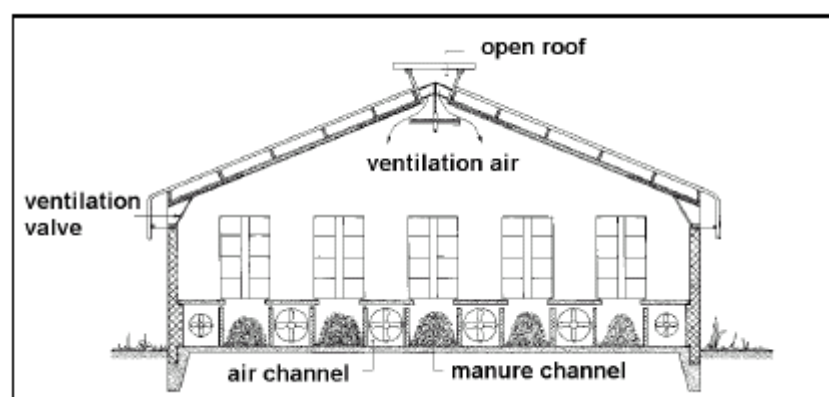

**Example of a canal system for laying hens**

**Applicability:** In Italy, this system is applied on large farms, as the labour input required is low. However, the system can only be applied in new houses, since it needs sufficient height for the manure storage, although it is possible that an appropriate existing building, such as an existing two-storey layer house, could possibly be converted into a high-rise house, but no information has been submitted to demonstrate this.

**Costs:** The extra investment costs of an additional ground floor are reported to be partially offset by the fact that no external storage is necessary. Extra investment costs compared with an open storage system amount to EUR 0.8 per bird place. Extra costs for energy are EUR 0.03/year per bird place. The total extra annual costs are EUR 0.12 per bird place per year. This means that with a reduction from 0.220 to 0.154 kg NH<sub>3</sub> per bird place per year (i.e. 30 %) approximately EUR 1.84 per kg NH<sub>3</sub> is abated.

**Reference farms:** Deep pit houses are used in several Member States (UK, Netherlands (2.5 million hens) and Italy (8 – 9 million hens)).

### **A3.1.2 Caged systems with manure removal, at least twice a week, by way of manure belts to covered storage (BREF 4.5.1.4)**

**Description:** The manure-belt battery is commonly applied throughout Europe. In this system the laying hens' manure is collected on manure-belts below the cages and transported to a closed storage at least twice a week. The manure is collected on manure-belts that are situated under each tier (or cage level). At the end of the belt a cross conveyor transports the manure further to the external storage. The manure-belts are made of smooth, easy-to-clean polypropylene or trevira and no residue sticks to these belts. With modern reinforced belts, manure can be removed from very long runs of cages. Some drying takes place on the belts, especially in summer conditions, and manure may be held on the belts for up to a week.

In improved belt systems, air is blown over the manure to achieve faster drying of the manure. The air is introduced just under each tier of cages, usually via rigid polypropylene ducts. Another benefit is the introduction of fresh cooling air immediately adjacent to the birds. Further improvements consist of the introduction of pre-warmed house air and/or the use of heat exchangers to pre-warm incoming outside air.

Having clean belts and effecting frequent manure removal to a closed storage ensures low ammonia emissions from the housing area. A modification to the cage system ensures the removal of manure, through adding extensions on the feed hopper that sweep the droppings onto the belt that runs between the cages. This system needs an additional storage facility.

**Achieved environmental benefits:** The environmental performance of this system depends on the frequency of manure removal, although it is certainly better than the scraper system, which usually leaves some manure behind. The higher the frequency of removal the lower the emission from the housing, e.g. if manure is removed at least twice a week a reduced emission of 0.035 kg NH<sub>3</sub> per bird place per year is reported. With a removal frequency of twice a day, the ammonia emission is reported to drop to 0.020 kg NH<sub>3</sub> per bird place per year. Because the manure is transported out of the house and there is no manure residue on the manure belts, a lower odour level is obtained, which improves the climate in the house. With this system no manure drying occurs and wet manure leaves the housing to be stored elsewhere or to be immediately applied on land.

**Cross-media effects:** Application of this system needs additional energy to run the belts. The lowest emission is achieved by both applying the scraping device to the feed hopper and by running the manure belt more frequently. It is assumed that any extra energy required is only due to running the manure belt more frequently.

**Operational data:** Wet manure is produced instead of dry manure. In the Netherlands this system is being phased out because of the high costs for selling this 'wet' manure and due to the relatively high ammonia emissions.

**Applicability:** Cages with manure belts can be used in new and existing buildings. They are usually applied with vertical tiered cages. The reference system would need full replacement. It is questionable whether the more frequent removal method can be considered an improvement compared to the more sophisticated systems available.

**Costs:** The extra investment costs of operating a twice-weekly removal compared with the open storage system are EUR 1.14 per bird place. The hopper construction required for a more frequent removal would require extra costs. These costs have not been reported. With a 58 % reduction of the emission (compared with the reference system) the relative costs are about EUR 23.6 per kg NH<sub>3</sub> abated. The extra operating costs per laying hen per year are

EUR 0.17.

**Reference farms:** In the Netherlands about 3.524 million hens are kept in these systems. This system is only occasionally installed in a new building. Data on the application of the system with the feed hopper construction have not been submitted.

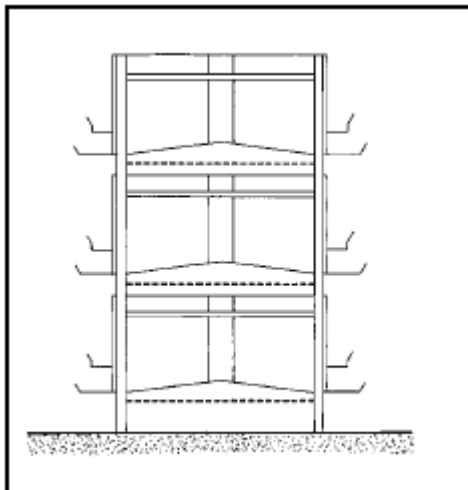

**Example of a manure-belt battery (3 tiers) with a belt under each tier to remove manure to a closed storage**

### **A3.1.3 Vertical tiered cages with manure belt with forced air drying, where the manure is removed at least once a week to covered storage (BREF 4.5.1.5.1)**

**Description:** The manure from the laying hens is collected on a manure belt, of which there is one for each tier. Over the belt a perforated tube is placed which blows air (which may be preheated) over the manure on the belt. The manure is removed from the house once a week to a covered storage outside the house, where the manure can be stored for longer. On some farms, manure is put into a container and removed from the farm within two weeks.

**Achieved environmental benefits:** When a forced drying system is installed with a drying capacity of 0.4 m<sup>3</sup> of air per laying hen per hour, then over a drying period of 7 days a dry matter content of the manure of at least 45 % is achieved. The NH<sub>3</sub> emission is 0.035 kg NH<sub>3</sub> per laying hen-place per year. No manure is left on the belts after removal.

**Cross-media effects:** Energy is required for operating the belts and the fans used to blow the air over the manure. Additional energy input is also required if preheating is applied. In modern cage houses, preheating is achieved by the application of a heat exchanger, in which outside air is drawn in and warmed up by the ventilation air that is emitted from the house. The level of extra energy input will vary; reported data show an extra 1.0 – 1.6 kWh per hen place per year used compared with the reference system, leading to a total energy use of 2 to 3 kWh per layer bird place per year.

**Operational data:** With this system it is possible to get a very low NH<sub>3</sub> emission and to reduce odour in the house. The preheated air dries the manure, but an additional benefit is that the climate in the cages close to the animals is very good. This allows better production results to be achieved than with the reference system.

**Applicability:** This system can be applied in new and existing buildings with 3 tiers or more. The aeration installation could possibly even be added to an existing belt cage system which does not have drying equipment, but no practical example has been submitted.

**Costs:** The cost when compared with the reference system, must take into account that external manure storage may be simpler (no slurry, but dry manure) and that in vertical tiered cages more birds can be housed. Depending on inclusion of these cost factors, the extra investment costs vary and are reported to be between EUR 0.39 (I) and EUR 2.05 (NL) per bird place per year. Additional energy costs will vary, as will the annual costs. Annual costs have been reported of EUR 0.193 (I) and EUR 0.57 (NL) per bird place per year. Cost efficiencies vary widely. For a 60 % reduction compared with the reference system, its application in Italy would cost EUR 1.45 per kg NH<sub>3</sub> abated, whereas in the Netherlands it would cost EUR 42.70 per kg NH<sub>3</sub> abated.

**Reference farms:** In the Netherlands 14.598 million hens are kept in this system. The system with the NH<sub>3</sub> emission of 0.035 kg per laying hen per year was developed about 12 years ago. Nowadays, this system is implemented in most new buildings and reconstructions.

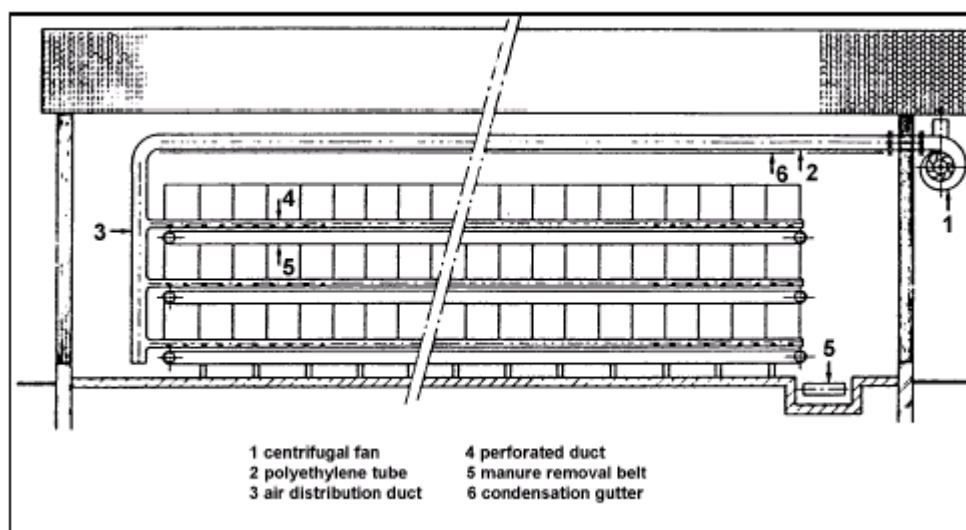

Schematic picture of a cage with forced (pneumatic) drying installation

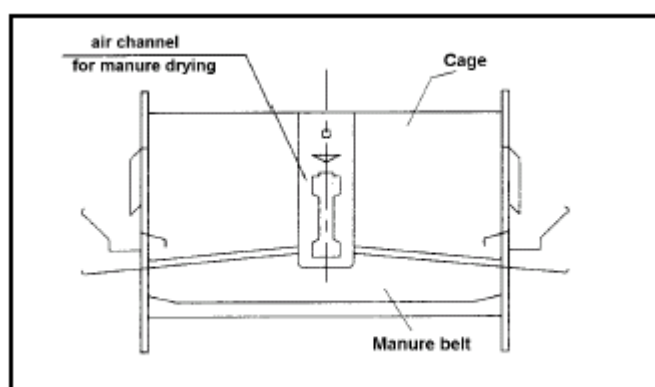

Schematic picture of a design incorporating two cages and with a manure belt and a drying channel

#### A3.1.4 Vertical tiered cages with manure belt with whisk forced air drying where manure is removed at least once a week to covered storage (BREF 4.5.1.5.2)

**Description:** This system has the same design principle as the previous system (3.1.3). A series of whisks are situated above the belt, with one whisk per set of two cages (back to back). Each whisk is operated by a connecting rod, which drives all the whisks in the row simultaneously, moving the air onto the manure on the belt. The difference from before is that

the drying air is not collected from the outside, but is just the internal air moved over the manure belt. This can be an advantage because there is no need to preheat the air or to use heat exchangers, as is the case with air recirculators (subsequently there is also no dust clogging problems as on the exchangers or in the air ducts). The manure is removed from the house once a week, with a dry matter content of at least 50 %.

**Achieved environmental benefits:** The emission from this system is about 0.089 kg NH<sub>3</sub> per bird place per year (I). This represents a 40 % reduction in comparison with the reference system, with an emission level of 0.220 kg NH<sub>3</sub> per bird place per year (I).

**Cross-media effects:** The energy consumption of moving the whisks is lower than the energy consumption of the perforated duct system. However, there is some noise associated with the whisk movement.

**Operational data:** As with the previous system (3.1.3), it is also possible to get low NH<sub>3</sub> emissions with this system. Because of the continuous air recirculation the climate in the house is good and the temperature throughout the house is uniform. Also, there appears to be less odour in the house in comparison with the previous technique.

**Applicability:** This system can be applied in new and existing buildings. It can be built in tiers, from 4 to 8. The whisk installation could possibly be added to an existing belt cage system which does not have drying equipment, but no practical example has been submitted.

**Costs:** Compared with the reference system, the extra investment is EUR 2.25 per bird place. The extra energy costs are 1.0 – 1.2 kWh per year per hen, which equates to 0.11 – 0.14 euros per year per bird place. The total extra costs (capital + running costs) are EUR 0.31 per bird place per year. This means, with a 60 % reduction of NH<sub>3</sub>-emission compared with the reference, costs of EUR 2.32 per kg NH<sub>3</sub> abated.

**Reference farms:** The system is currently being implemented on some large poultry farms in Italy. Approximately 700000 to 800000 laying hens are kept in this system.

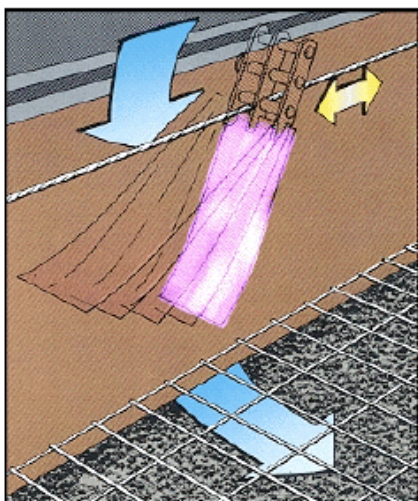

**Principle of whisk-forced air drying**

#### **A3.1.5 Vertical tiered cages with manure belt with improved forced air drying where the manure is removed from the house at least once a week to covered storage (BREF 4.5.1.5.3)**

**Description:** The principle is as described in A3.1.3. The manure is removed from the house once every five days to a covered container that must be removed from the farm within two weeks. Drying manure in this system requires the installation of a forced drying system with a

drying capacity of 0.7 m<sup>3</sup> per laying hen per hour and an air temperature of 17 °C. The maximum drying period is 5 days, and the manure must have a dry matter content of at least 55 %.

**Achieved environmental benefits:** The NH<sub>3</sub> emission from this system is 0.010 kg NH<sub>3</sub> per laying hen-place per year (NL) to 0.067 kg NH<sub>3</sub> per laying hen-place per year (I).

**Cross-media effects:** Odour levels in the house are perceived to be relatively low. Noise levels are considered to be similar to that of the system described earlier in 3.1.3. A high input of energy is required to dry the manure compared with the other air drying systems, but this can be reduced by preheating the incoming air. Dust levels are lower than in the other housing systems.

**Operational data:** With this system it is possible to get very low NH<sub>3</sub> emissions from the housing. Where the air is preheated, the manure becomes drier and the climate in the cages close to the animals improves, also leading to better production results. In modern laying houses preheating the drying air is done with a heat exchanger, in which the outgoing drying air warms the incoming air.

**Applicability:** This system can be applied in new and existing buildings. It can be built in tiers, from 3 to 10. There is no information about existing belt-systems being additionally equipped with this drying system.

**Costs:** This system is a low-cost system aimed at sites with large numbers of birds wanting to make efficient use of the available space with high stocking densities. However, large differences in costs have been reported. The lower costs reported by Italy are partly due to the extra revenue generated by the higher egg prices which were applied to help offset the costs of applying the improved system. The extra investment compared to the reference system varies between EUR 0.65 (I) and EUR 2.50 (NL) per laying hen-place. Annual costs per laying hen per year vary between EUR 0.365 and 0.80 (including electricity costs). With a 70 – 88 % reduction of ammonia emission compared to the reference system, the cost efficiency varies between EUR 2.34 and 34.25 per kg NH<sub>3</sub> abated.

**Reference farms:** The system was developed in the late nineties. Currently, in the Netherlands about 2 million laying hens are kept in this system. Nowadays, these systems employing forced drying on the manure belts are implemented on large enterprises in new buildings, and in building conversions.

#### **A3.1.6 Vertical tiered cages with manure belt with drying tunnel over cages, after 24-36 hours, the manure is removed to covered storage (BREF 4.5.1.5.4)**

**Description:** The design of the installation is similar to the previous air-dried belt systems in principle. The manure is collected on the belts under the cages and taken to one end of the row of cages. From here it is lifted up to drying belts within a drying tunnel above the cages, the drying tunnel running along the whole length of the row of cages. The manure is spread on the belts in the tunnel, where it dries. At the end of a complete run from one end of the tunnel to the other, the manure is discharged from each belt to the lowest belt inside the tunnel, which collects all the dried droppings and makes a last run to the opposite end. This action means that by the end of a full run the manure has a high dry matter content. The tunnel is ventilated by a centrifugal fan, which emits the air out of the roof through a chimney. The drying air is taken from inside the house, at the two opposite ends of the tunnel. The belts are moved every few minutes and the whole run inside the tunnel takes 24 – 36 hours.

**Achieved environmental benefits:** Ammonia emission has been reported to be 0.015 (NL) to 0.045 (I) kg NH<sub>3</sub> per bird place per year. The manure can reach a very high dry matter content of close to 80 %.

**Cross-media effects:** Energy is required for ventilating the drying tunnel. The actual energy input will depend on the size of the installation (number of cages) and the resistance to airflow in the tunnel itself. Further information is needed to assess how changes in the design and operation might affect the energy requirements. By drawing away the inside air, the level of odour is thought to be very low.

**Operational data:** This system is typically operated in combination with house ventilation. Both ventilation systems will have to be synchronised so as to avoid any interference, as this could affect the operation of the tunnel system.

**Applicability:** It has been applied to cage systems with 4 to 6 tiers. The refurbishing or conversion of existing cage systems has not been reported, but application in existing buildings will require adaptations to the roof to add chimneys to exhaust the drying air. The height of the chimneys will affect the fan capacity and the energy input. Also, external storage of the dried manure is required (containers or other).

**Costs:** Costs are reported from Italy. The extra investment is EUR 2.79 per bird place. The extra costs for energy are 2.0 – 2.5 kWh per year per hen, equalling EUR 0.23 – 0.28 per bird place per year. The total extra costs (capital + running costs) are EUR 0.48 per bird place per year. This means, that for a 80 % reduction of NH<sub>3</sub>-emission compared to the reference system, EUR 2.74 per kg NH<sub>3</sub> abated.

**Reference farms:** In Italy, approximately 1 million laying hens are kept in this system.

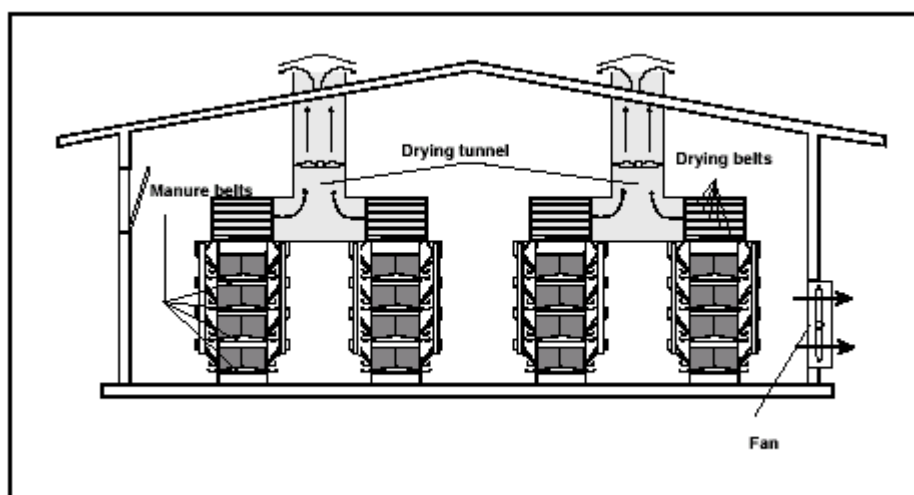

**Schematic picture of a drying tunnel over vertical tiered cages**

### **A3.1.7 Barn and free-range systems with deep litter system with forced air drying (BREF 4.5.2.1.2)**

**Description:** This is based on the deep litter system for laying hens (described below) but here the ammonia emission is reduced by applying forced ventilation. Forced ventilation is applied through tubes that blow 1.2 m<sup>3</sup> of air per bird place per hour at a temperature of 20 °C over the manure stored under the slats or over the manure being removed by the (aerated) belts.

(Deep litter system description: The layer house is a traditional building with respect to walls, roof and foundation. Thermally insulated poultry houses have forced ventilation; either windowless or with windows for natural daylight. Birds are kept in large groups with 2000 to 10000 bird places per housing facility. The air is replaced and emitted passively by natural ventilation or by forced ventilation with negative pressure. In accordance with EU Egg Marketing Standards currently in effect, at least one third of the floor area (concrete floor) must be covered with bedding (chopped straw or wood shavings used as litter material) and two thirds arranged as droppings (manure) pit. The pit is covered with slats that are mostly made of wood or artificial material (wire meshing or plastic lattice) and slightly raised. Laying nest, feed installation and the water supply are placed on the slats to keep the litter area dry. The manure is collected in a pit below the slats during the laying period (13 – 15 months). The pit is formed by the raised floor or can be sunk into the ground. Automatic supply of feed and drinking water, with long troughs or automatic round feeders (feeder pans) and nipple drinkers or round drinkers are installed above the pit area. Droppings are removed from the pit at the end of a given laying period; or intermittently, with the aid of (aerated) manure-belts. At least one third of the used-air volume stream is drawn off via droppings pit. Individual or community nests are provided for laying; automatic egg collection is also possible. Lighting programmes to influence performance/rate of lay and crude protein adapted feeding may be applied.)

**Achieved environmental benefits:** The application of forced ventilation and quick drying of the manure reduces emissions to 0.125 kg NH<sub>3</sub> per bird place per year for the pit storage. The ammonia reduction of this system is 60 % compared to the reference system (0.315 kg NH<sub>3</sub>). Frequent removal with (aerated) manure belts can be expected to give even lower emission levels.

**Cross-media effects:** Reduced odour levels can be expected compared to the reference system. The energy input in this system is high, because a heating system must be installed to achieve the 20 °C temperature necessary in the tubes. Extra energy is also required to maintain the airflow. Air is drawn in through inlets in the sidewalls and through an open ridge construction in the roof.

**Operational data:** Management of this system is principally the same as of the reference deep litter design.

**Applicability:** The system can only be used in laying hen houses with enough space underneath the slats. Traditionally the manure pit has a depth of 80 cm, but when using this system it is necessary to add an extra 70 cm. The experience from farmers already using the deep floor system is that they like this type of system because it requires very little change to the traditional design.

**Costs:** Compared with the reference system, the extra investment costs are EUR 1.10 per bird place. The extra annual costs are EUR 0.17 per bird place. This means that with a 60 % ammonia reduction (0.315 to 0.125 kg NH<sub>3</sub>), the cost is about EUR 5.78 per kg NH<sub>3</sub> abated.

**Reference laying hen-places:** This system is very new; only one farm (40000 laying hens) in the Netherlands uses this system and about 5 % of the farms in Germany. It is expected that application of this system will increase in the future.

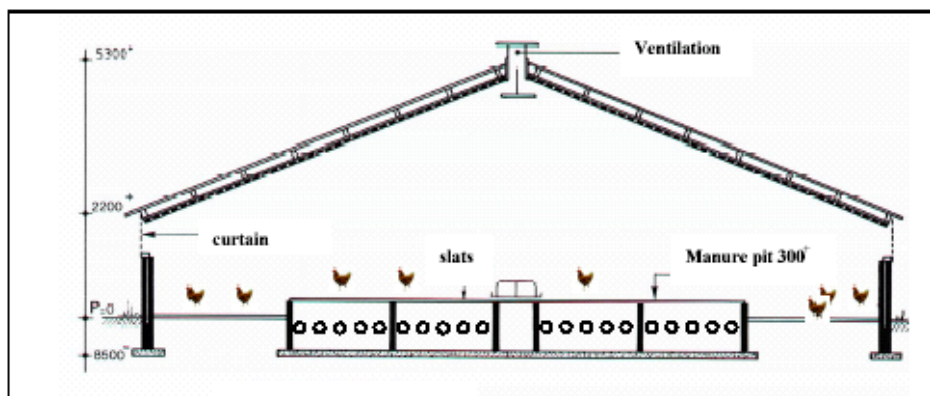

### Deep litter systems with forced drying via tubes under the slatted floor

#### A3.1.8 Barn and free-range systems with deep litter system with perforated floor and forced air drying (BREF 4.5.2.1.3)

**Description:** The layer house is traditional (walls, roof, etc.) The ratio of litter to “slatted floor” is 30:70. The laying nest area is included in the slatted floor area. There is a perforated floor underneath the manure and the slats, which allows transportation of the air used to dry the manure on top of it. The maximum load of this perforated floor is 400 kg/m<sup>2</sup>. The distance between the bottom of the pit and the perforated floor (air-channel) must be 10 cm. The perforated floor has a total area of air openings of 20 % of the surface area.

**Achieved environmental benefits:** It is possible to obtain a 65 % reduction in NH<sub>3</sub>-emissions (0.110 kg compared to the 0.315 kg NH<sub>3</sub> per bird place per year of the reference system).

**Cross-media effects:** Higher energy input is required because of the forced ventilation.

**Operational data:** The layer droppings fall through the slats onto the perforated floor. At the beginning of the laying period the perforated floor is provided with a 4 cm thick bed of woodshavings. The (preheated) air is blown from beneath through the small openings in the perforated floor under the manure. To dry the manure properly, ventilators with a total capacity of 7 m<sup>3</sup> air/hour at 90 Pascal are installed. The manure stays on the perforated floor for about 50 weeks (laying period) and is then taken out of the house. The minimum distance between the perforated floor and the slats is 80 cm. The manure is dried constantly by the continuous flow of air. The dry matter content of the manure is about 75 %. The farmer should protect himself with a face mask. The drinking facilities must be installed on top of the slats, but good design of the tubes should avoid loss of water.

**Applicability:** Application in new situations is more likely, but it could also be installed in existing houses, but at an additional cost.

**Costs:** Investment costs are EUR 1.20 per birdplace and annual costs are EUR 0.18 per bird.

**Reference farms:** In the Netherlands, about 10 farms (year 2001) are currently applying this system.

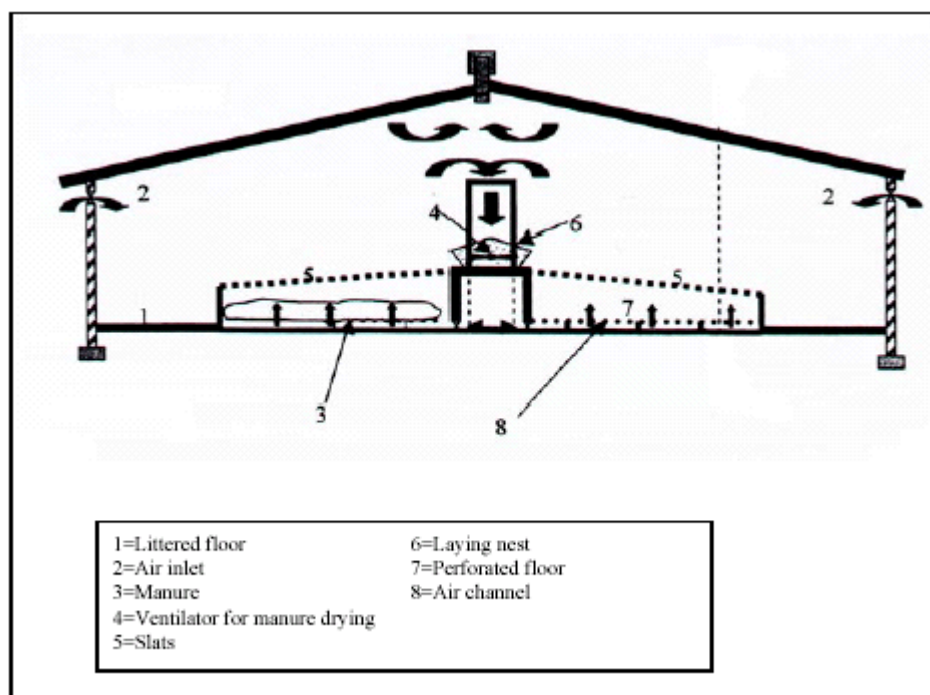

### Deep litter system with perforated floor and forced manure drying

#### A3.1.9 An aviary system with or without range and or outside scratching area (BREF 4.5.2.2)

**Description:** This poultry house is a construction with thermal insulation and forced ventilation, either windowless, or with windows for natural daylight and artificial light for applying lighting programmes; houses can be combined with range and outside scratching area. Birds are kept in large groups and enjoy freedom of movement over the entire house area. Housing space is subdivided into different functional areas (feeding and drinking, sleeping and resting, scratch area, egg laying area). The birds can use several house levels that allow for higher stocking densities compared to the commonly used floor regime (deep litter). Droppings are removed via manure belts into containers, or into a manure pit, or otherwise collected in a manure pit. Litter is spread onto a fixed concrete area. Feed (mostly feed chains) and drinking water (nipple or cup drinkers) are automatically supplied. Laying nests (individual or community nest design) have manual or automatic egg collection. Stocking density is maximised to 9 birds per usable m<sup>2</sup> or to 15.7 birds per ground surface (in m<sup>2</sup>), with houses accommodating between 2000 and 20000 birds (bird places).

**Achieved environmental benefits:** Data on ammonia emissions have only been reported by the Netherlands, with values of 0.09 kg NH<sub>3</sub> per bird place per year, which is 71 % less than the reference non-cage system. This emission reduction is related to the manure removal, where about 90 % of all the manure is removed by belts at a frequency of at least once a week. The other 10 % of the manure is removed from the litter area after one cycle.

**Cross-media effects:** When compared to the cage regime, a distinctly higher dust content in the in-house air is reported. This gives a higher stress effect on the mucous membranes of humans and animals. Energy requirements depend particularly on the ventilation and vary between 2.70 kWh per bird place per year for non-belt systems to 3.70 kWh per bird place per year for aerated manure belt systems.

**Operational data:** Hens enjoy more freedom of movement than their counterparts under cage management, but replacement pullets must come from aviary grower houses. Aviary systems are more bird-friendly than, by comparison, conventional floor management systems, since the hens' living space is more heavily structured. More favourable temperature conditions in winter are observed due to a higher stocking density. Feed conversion and the rate of lay are also better than in floor regimes. The available in-house space can be supplemented by providing an outside scratching area. However, the birds can have contact with faeces, which creates a hazard from intestinal parasites. Also, the system shows a higher percentage of soiled and/or "laid-away" eggs. Another negative effect is that having larger groups and introducing natural daylight also promotes aggressive bird behaviour and incidences of feather pecking and cannibalism are possible, resulting in a higher potential loss rate. Bird observation is more difficult and medication requirements tend to be higher.

**Applicability:** Aviary housing systems are still little used compared with cage or floor regimes, but a reasonable amount of practical experience has been gathered. Since there is no significant demand for eggs from house-confined aviary systems, in Germany this housing system is currently only practised in combination with outdoor ranges.

**Costs:** Costs for the design with aerated manure belt removal total EUR 16.5 to 22.0 per bird place per year:

- labour EUR 1.2 – 2 (at EUR 12.5/hr)
- capital investment EUR 2.4 – 5.6 (11 % annual cost: 5 % depreciation, 2.5 % repair and maintenance, 7 % interest)
- operating cost EUR 12.9 – 14.4 [124, Germany, 2001]

Total costs EUR 16.5 – 22.0

**Driving force for implementation:** The implementation of aviary systems may increase for animal welfare reasons. Another driving force might be the decision of the EC (Commission Regulation No 1651/2001) that, in order to indicate the farming method, no terms may be used on eggs other than 'free range', 'barn' or 'cage'.

**Reference farms:** In general, the number of houses with aviary systems is small. Data reported by the Netherlands show that about 3 % (649000) of the layers are kept in aviaries and on less than 1 % of the farms.

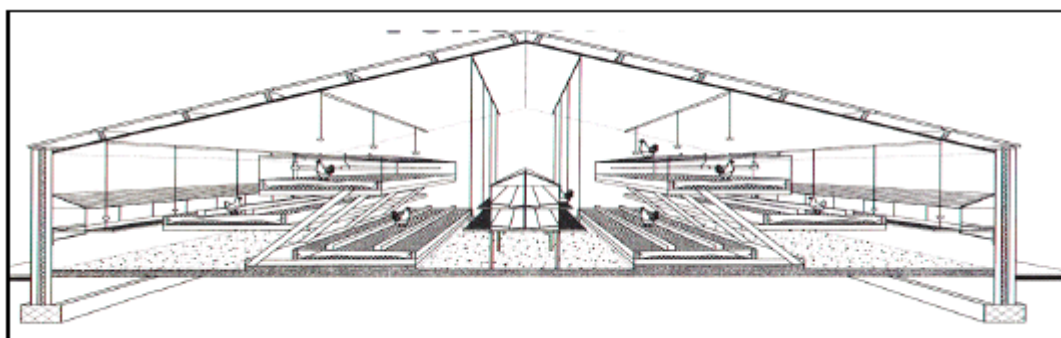

**Schematic of an aviary system**

## **A3.2 Broilers and floor reared replacement pullets**

### **Naturally ventilated house with a fully littered floor and equipped with non-leaking drinking systems or a well-insulated fan ventilated house with a fully littered floor and equipped with non-leaking drinking systems (BREF 4.5.3)**

The traditional housing of intensive broiler production is a simple closed building construction of concrete or wood with natural light or windowless with a light system, thermally insulated and force-ventilated. Buildings are also used that are constructed with open sidewalls (windows with jalousie-type curtains); forced ventilation (negative pressure principle) is applied by way of fans and air inlet valves. Open houses must be located so that they are freely exposed to a natural stream of air and are positioned at a right angle to the prevailing wind direction. Additional ventilating fans operate via ridge slots, and gable openings may apply. This is intended to provide the in-house broiler area with extra air circulation during hot spells in summer. Mesh wire screens along upper sidewalls keep wild birds out.

Closed buildings have oil- or gas-fired warm-air blowers for total room heating; radiant heaters are used for zonal heating in houses built for open-air ventilation. Artificial lighting and/or artificial/natural daylight combination lighting system are provided as required.

Broilers are kept on litter (chopped straw, wood shavings or shredded paper) spread over the entire house floor area which, in turn, is built as a solid concrete slab. Manure is removed at the end of each growing period. Automatic, height-adjustable feeding and drinking systems (mostly tube feeders with round feeder pans and nipple drinkers with drip water catch bowls) are applied. Crude protein-adapted feed is given. Broilers are kept at a stocking density of 18 to 24 birds per m<sup>2</sup>. Stocking density is also measured in kg live weight/m<sup>2</sup> (e.g. in Finland), but this number is variable. New legislation is expected to limit the stocking density of broilers. Houses can stock between 20000 and 40000 birds.

Both for animal welfare reasons and to minimise ammonia emissions wet litter must be avoided. The dry matter content of the litter depends on:

- the drinking system
- length of the growing period
- the stocking density
- the use of floor insulation.

In the Netherlands a new housing technique was designed to avoid or minimise wet litter. In this improved design (known as VEA-system, the Dutch abbreviation for “broiler low emission housing”) attention is paid to the insulation of the building, to the drinking system (to avoid spillage) and to the application of wood shavings/sawdust. However, accurate measurements in fact show that both the traditional system and the VEA-system have the same ammonia emissions of 0.08 kg NH<sub>3</sub> per broiler place per year (NL).

The emission level 0.08 kg NH<sub>3</sub> per broiler place per year is considered as the reference level. It is obvious that as the ventilation rate depends on the natural airflow, design of the house and both the air inlets and outlets is crucial. Energy consumption (and costs) is lower than with the fan-ventilated house.

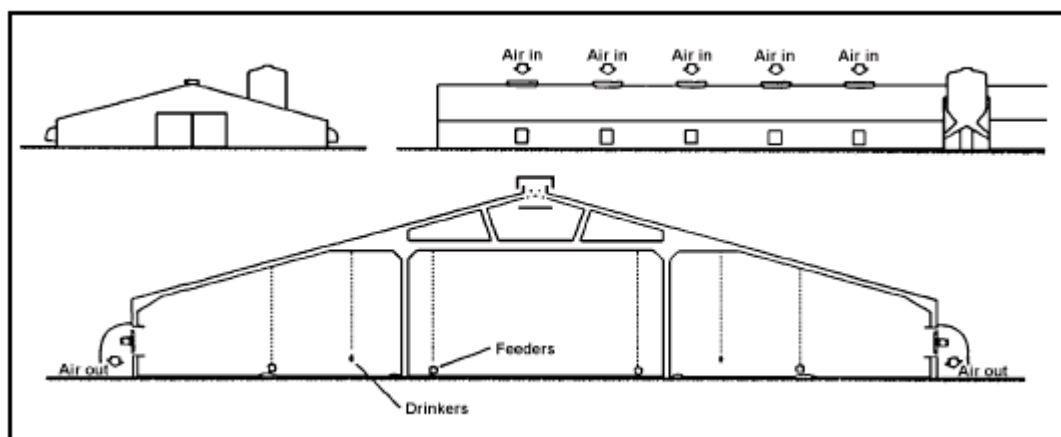

**Schematic cross-section of a traditional closed broiler house**

### **A3.3 Turkeys**

**Naturally ventilated house with a fully littered floor and equipped with non-leaking drinking systems or a well-insulated fan ventilated house with a fully littered floor and equipped with non-leaking drinking systems (BREF 4.5.3)**

The commonly applied turkey housing is a traditional housing construction, which is very similar to the housing of broilers (see A3.2 above for details). Turkeys are housed in closed, thermally insulated buildings with forced ventilation, or (more frequently) in open (outdoor-climate) houses with open sidewalls and jalousie-type curtains (unrestricted natural ventilation). Forced ventilation (negative pressure) is applied by fans and inlet valves. Free open-air ventilation is created via automatically controlled jalousies or wall-mounted inlet valves. Open houses are aligned at right angles to the prevailing wind direction and located in such a way as to be exposed to natural airflow. Additional ventilation is applied via ridge slots and gable openings. Radiant gas heaters are applied for heating.

Precautions are put in place to protect against emergencies like power cuts, extreme weather conditions or fire, as per unit a large number of birds will always be at risk. During peak summertime temperatures, additional measures are taken to minimise heat stress on the birds (by providing for larger-volume air change, operating extra fans for bird comfort in open houses, water fogging or roof sprinkling)

Wire meshing in the upper sidewall section is applied to keep wild birds out. A floor regime is operated with litter material (chopped straw, wood shavings) spread over the entire house floor area (built of concrete) with layers up to 9 – 12 inches deep. Manure removal and cleaning of the house takes place at the end of each respective growing period. All litter is removed by an excavator or frontloader. Litter replenishment is applied as needed. Automatic height-adjustable round drinkers and feeders are applied during the growing/feeding period. Daylight length and light intensity can be controlled during brooding and, in closed houses, over the entire brooding/finishing period.

## **A3.4 Ducks**

**Unrestricted naturally ventilated house or a well insulated fan ventilated house with a partly-slatted floor with impermeable drainage channels and effluent storage area or**

**A fully slatted floor with impermeable drainage channels and effluent storage area or**

**A fully littered floor with a water system positioned above a gully and covered drainage channels and effluent storage areas (BREF 2.2.3.2)**

Ducks are kept in housing, although in some Member States outdoor rearing is also allowed. There are three main housing systems for fattening of ducks:

- fully littered, with a water system positioned above a gully
- partly slatted/partly litter
- fully slatted.

The commonly applied duck house is a traditional housing system and is similar to the broiler house (see A3.2 above for details). It has a concrete floor that is covered with litter. The house is equipped with a ventilation system (natural or mechanical) and, depending on the climatic conditions, heating is applied.

Production cycles will vary between Member States. In Germany, the production cycle for duck meat production is divided into a growing period up to day 21 followed by a finishing period until day 47 – 49. Rearing and growing is done in separate stalls. Manure is removed and the stalls are cleaned and disinfected during a service period of about 5 to 7 days before they are stocked again. Stocking density is 20 kg live weight/m<sup>2</sup> accessible floor area in both phases, with accessible areas typically measuring 16 x 26 m for growing and 16 x 66 m for finishing. Thus, the growing stalls can house approximately 20000 young ducks and the finishing stalls about 6000 ducks.

Commonly applied is the fully littered system using wheat or barley straw or wood chips. The layer is usually not too thick because the manure of ducks is much wetter than that of chicken broilers. Slats, if applied, are usually of plastic-coated wire, wood or synthetic material.

## Appendix 4 Rule under development

The following rule about minimising pollution from, and accumulation of, phosphorus from the application of organic manures is under discussion by the pig and poultry steering groups. The development of the Programme of Measures under the Water Framework Directive will influence this rule.

### Phosphorus

The basis for this draft rule is the Code of Good Agricultural Practice for the Protection of Water.

Where manures are applied on fields at ADAS Soil P index of 3 or above, total P inputs shall not exceed the amount removed by crops in the rotation.

This means that some fields will receive less than 250 kg/ha N in organic manures in any particular year to avoid excessive enrichment of soil P levels.

In certain areas of the UK up to three times as much land could be required for spreading.

There is some concern that the Olsen's P measurement of phosphorus, on which the Defra code is based, may not be the best way of assessing environmental risk.

Scotland uses a different basis to measure soil phosphorus.

More work is required to ensure that the rule is both practical to apply to the majority of farms.